

Fully-Integrated Power Bank System-On-Chip with 2.1A charger, 2.1A discharger

Features

- **Switch buck charger and boost**
 - ◇ 2.1A Synchronous switching charger and 5V 2.1A boost converter
 - ◇ Boost converter efficiency up to 96%
 - ◇ Switching charger efficiency up to 97%
 - ◇ Integrated power-path management, charging batteries and charging cellphones at the same time
- **Charger**
 - ◇ Adaptive charging current control, excellent adapter compatibility
 - ◇ Charger voltage accuracy $\pm 0.5\%$
 - ◇ Support 4.20/4.30/4.35/4.40V batteries
- **State of charge (SOC) indicator**
 - ◇ Integrated LED controller supports 4/3/2/1 LEDs as the SOC indicator
- **Fully featured**
 - ◇ Key ON/OFF
 - ◇ Integrated flashlight controller
 - ◇ Integrated cellphone plug-in and plug-out detector
- **Low power**
 - ◇ Smart load detector, switching to standby mode automatically
 - ◇ $< 100 \mu\text{A}$ standby current
- **Ultra simplified BOM**
 - ◇ Integrated power FET, charging/boosting with a single inductor
- **Multiple protections, high reliability**
 - ◇ Output over-current, over-voltage, short-circuit protection
 - ◇ Input over-voltage, over-current, battery over-charge, over-drain, over-current protection
 - ◇ Thermal Shutdown
 - ◇ ESD 4KV

Applications

- **Power bank, Portable Charger**
- **Mobile Phones, Smart Phones, Handheld Devices, Portable Media Player, Tablet**

Description

IP5306 is a fully-integrated multi-function power management SoC. It integrates a boost converter, a Li battery charger management system and a battery state of charge indicate controller. It provides a turn-key solution for power bank and portable charger applications.

IP5306's high integration and rich features make the minimized component number in application. It can effectively downsize the application and lower the BOM cost.

IP5306 only needs a single inductor to realize step-down and step-up which provides 2.1A output current. It can switch to standby mode at light load automatically

IP5306's synchronous switching charger provides 2A charging current. Its efficiency is up to 97%. It regulates the charging current by IC temperature and input voltage.

IP5306 integrates voltage based fuel gauge indication of 1/2/3/4 LEDs and flashlight function.

IP5306 is available in eSOP8L

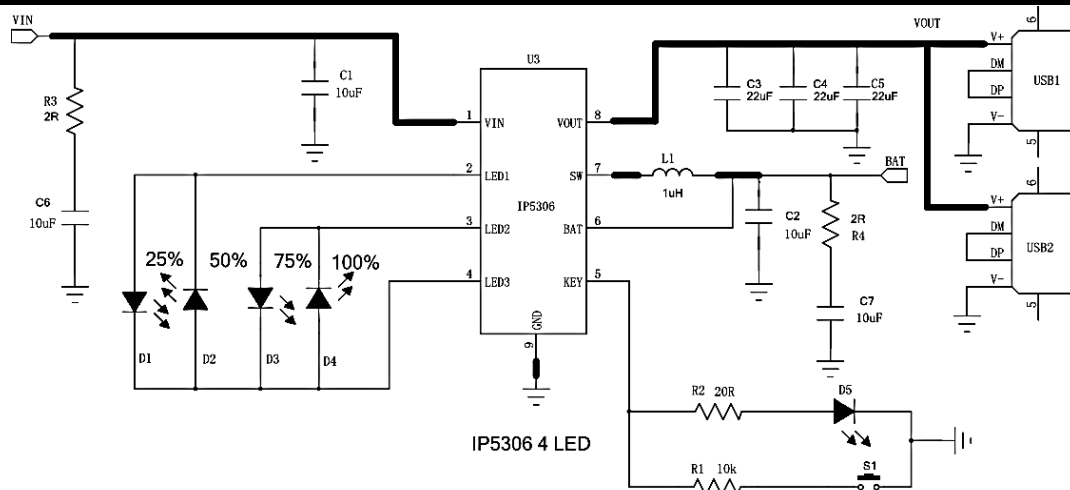

如果不需要照明功能，R2和D5可以省略

图 1 Simplified application schematic (4 LEDs as the SOC indicator)

Pin Definition



图 2 IP5306 Pin Diagram

Pin Name	Pin Number	Pin Description
VIN	1	Charger 5V input pin
LED1	2	Battery indicator pin1
LED2	3	Battery indicator pin2
LED3	4	Battery indicator pin3
KEY	5	ON/OFF key input, multiplex torch lighting driver
BAT	6	Battery voltage sense pin
SW	7	DCDC switch node, connect inductor
VOUT	8	DCDC 5V output pin
PowerPAD		Connect to GND

The PartList of PowerBank SoC

PartNum	charger	Boost	LEDs	Torch	KEY	I2C	DCP	Type-C	Quick Charge	Package
IP5303	1.0A	1.2A	1,2	✓	✓	-	-	-	-	eSOP8
IP5305	1.0A	1.2A	1,2,3,4	✓	✓	-	-	-	-	eSOP8
IP5306	2.4A	2.1A	1,2,3,4	✓	✓	✓	-	-	-	eSOP8
IP5108	2.0A	2.0A	3,4,5	✓	✓	✓	-	-	-	eSOP16
IP5308	2.4A	2.1A	1,2,3,4	✓	✓	✓	✓			eSOP16
IP5207T	1.2A	1.2A	1,2,3,4	✓	✓	✓	✓	-	-	QFN24
IP5109	2.1A	2.1A	3,4,5	✓	✓	✓	-	-	-	QFN24
IP5209	2.4A	2.1A	3,4,5	✓	✓	✓	✓	-	-	QFN24
IP5219	2.4A	2.1A	1,2,3,4	✓	✓	✓	✓	✓	-	QFN24
IP5312	15W	3.5A	2,3,4,5	✓	✓	✓	✓		✓	QFN32
IP5318Q	18W	4.8A	2,3,4,5	✓	✓	✓	✓		✓	QFN40
IP5318	18W	4.8A	2,3,4,5	✓	✓	✓	✓	✓	✓	QFN40

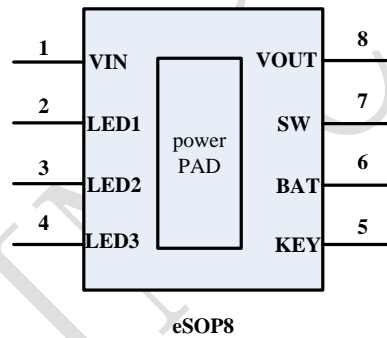
Absolute maximum ratings

Parameter	symbol	value	Unit
Port input voltage range	V_{IN}	-0.3 ~ 5.5	V
Operating free-air temperature range	T_A	0 ~ 70	°C
Junction temperature	T_J	-40 ~ 150	°C
Storage temperature	T_{stg}	-60 ~ 150	°C
Thermal resistance (from junction to ambient air)	θ_{JA}	40	°C/W
Human-body model (HBM)	ESD	4	KV

* Stresses beyond those listed under absolute maximum ratings may cause permanent damage to the device. These are stress ratings only, and functional operation of the device at these or any other conditions beyond those indicated under recommended operating conditions is not implied. Exposure to absolute-maximum-rated conditions for extended periods may affect device reliability.

Recommended operation conditions

Parameter	symbol	MIN	Typical	MAX	Unit
Input voltage	V_{IN}	4.75	5	5.5	V
Load current	I	0	2.1	2.6	A
Operating ambient temperature	T_A	0	--	70	°C

*Beyond these operation conditions, the device's performance will not be guaranteed

Electrical Characteristics

TA=25°C, L=1uH unless otherwise noted

Parameter	symbol	Test condition	MIN	TYP	MAX	Unit
Charger system						
Input voltage	V_{IN}		4.75	5	5.5	V
Input current (charging)	I_{VIN}	VIN=5V, fs=500KHz		2		mA
Input current (standby)		VIN=5V, Device not switching		100		uA
Target charge voltage	V_{TRGT}			4.2		V
Charge current	I_{CHRG}			2.1		A
Trickle charge current	I_{TRKL}	VIN=5v, BAT=2.7v		100		mA
Trickle charge stop voltage	V_{TRKL}			2.9		V
Recharge threshold	V_{RCH}			4.1		V
Charger safety timer	T_{END}			24		Hour
Input under-voltage protection	V_{UVLO}	Rising voltage		4.5		V
Input under-voltage protection hysteresis	V_{UVLO}			200		mV
Boost system						
Battery operation voltage	V_{BAT}		3.0		4.4	V
Battery operation current	I_{BAT}	VBAT=3.7V, VOUT=5.1V, fs=5000KHz		3		mA
		VIN=5V, Device not switching		100		uA
DC-DC output voltage	V_{OUT}	VBAT=3.7V		5.10		V
Output voltage ripple	ΔV_{OUT}	VBAT=3.7V, VOUT=5.0V, fs=500KHz	50	100	150	mV
Boost output current	I_{vout}			2.1		A
Load over-current detect timer	T_{UVD}	Output voltage continuously lower than 4.4V		30		ms
Load short-circuit detect timer	T_{OCD}	Output current continuously larger than 3.5A	150		200	us
Control system						
Switching frequency		Switching frequency		500		KHz
PMOS on resistance	r_{DSON}			35		mΩ
NMOS on resistance				30		mΩ

Battery standby current	I_{STB}	$V_{IN}=0V, V_{BAT}=3.7V$	50		μA
LED lighting current	I_{light}		25		mA
LED indicator current	I_{L1} I_{L2} I_{L3}		4		mA
Load removal detect timer	T_{loadD}	Load current continuously lower than 45mA	32		s
Push-button wake-up timer	$T_{OnDebounce}$		50		ms
Push-button light-on timer	$T_{Keylight}$		2		s
Thermal shutdown	T_{OTP}	Rising temperature	125		$^{\circ}C$
Thermal shutdown hysteresis	ΔT_{OTP}		40		$^{\circ}C$

State Of Charge (SOC) indication

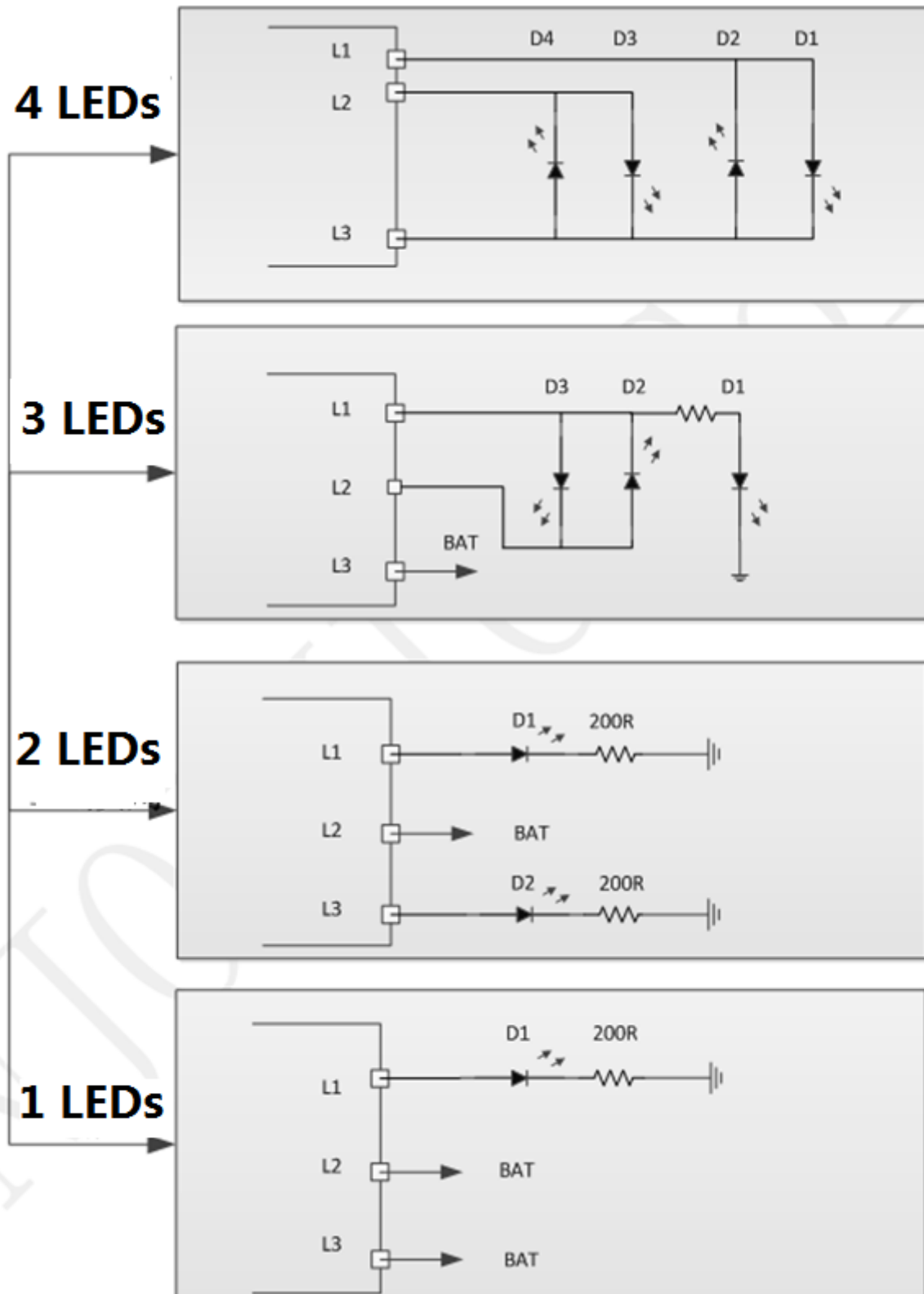

■ 4 LEDs mode

Discharging mode, 4 LEDs as the indicator

SOC (%)	L1	L2	L3	L4
$SOC \geq 75\%$	ON	ON	ON	ON
$50\% \leq SOC < 75\%$	ON	ON	ON	OFF
$25\% \leq SOC < 50\%$	ON	ON	OFF	OFF
$3\% \leq SOC < 25\%$	ON	OFF	OFF	OFF
$0\% < SOC < 3\%$	1.5Hz blink	OFF	OFF	OFF
$SOC = 0\%$	OFF	OFF	OFF	OFF

Charging mode 4 LEDs as the indicator

SOC (%)	L1	L2	L3	L4
Full	ON	ON	ON	ON
$75\% \leq SOC$	ON	ON	ON	1.5Hz blink
$50\% \leq SOC < 75\%$	ON	ON	1.5Hz blink	OFF
$25\% \leq SOC < 50\%$	ON	1.5Hz blink	OFF	OFF
$SOC < 25\%$	1.5Hz blink	OFF	OFF	OFF

■ 3 LEDs mode

The displays of 3 LEDs is similar to that of 4 LEDs. The corresponding SOC of each LED is presented in the following table.

	D1	D2	D3	D4	D5
3 LEDs	3%	66%	100%	NA	NA
4 LEDs	25%	50%	75%	100%	NA

■ 2 LEDs Mode

	state	LED1	LED2
Charging	In charging	Blink	OFF
	End of Charge	ON	OFF
Boost	In discharging	OFF	ON
	Low Battery	OFF	Blink

■ 1 LED Mode

	状态	LED1
Charging	In charging	Blink
	End of Charge	ON
Boost	In discharging	ON
	Low Battery	Blink

Push Button

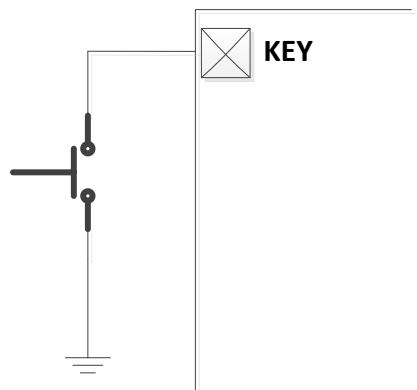

Figure 1 KEY button

Push button's connecting is shown in Fig 5. IP5306 can identify long push and short push.

- If button is pushed longer than 30ms but shorter than 2s, IP5306 will identify the action as short push. Short push will open SOC indicator LEDs and step-up converter
- If button is pushed longer than 2s, IP5306 will identify the action as long push. Long push will close step-up converter, SOC indicator LED and flashlight LED.
- If button is pushed shorter than 50ms, IP5306 will ignore the action.
- If two short push is detected within 1s, IP5306 will open or close flashlight LED

Typical Application Schematic

IP5306 only needs capacitors, resistors, and inductors to realize a full featured power bank solution.



图 7 4 LEDs SOC indicator typical application schematic

Package information

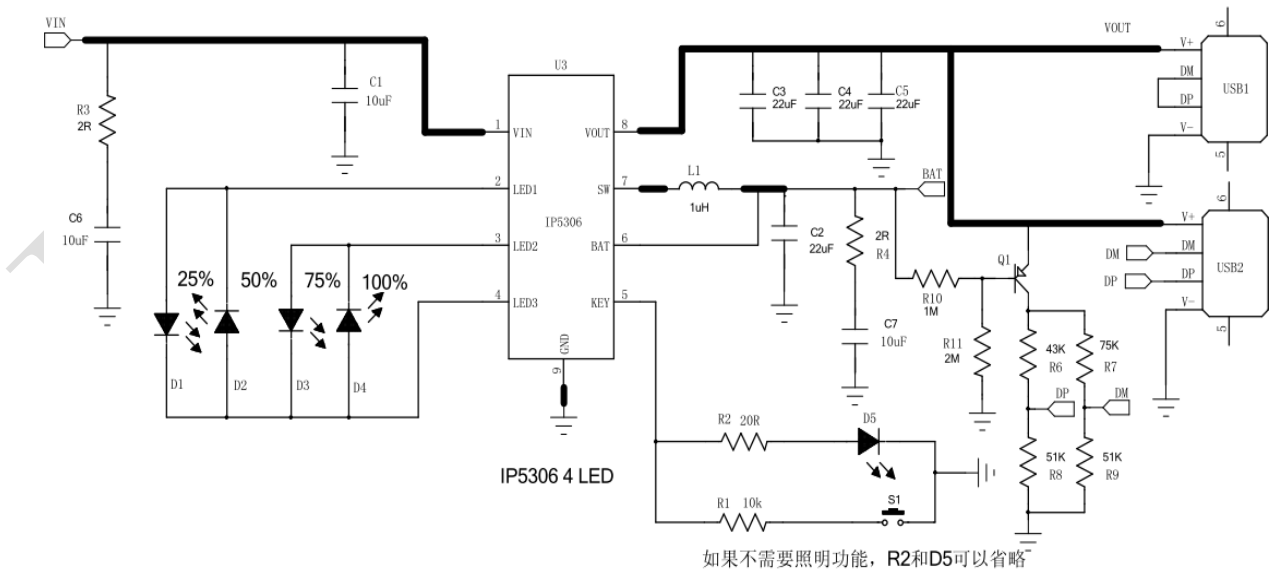
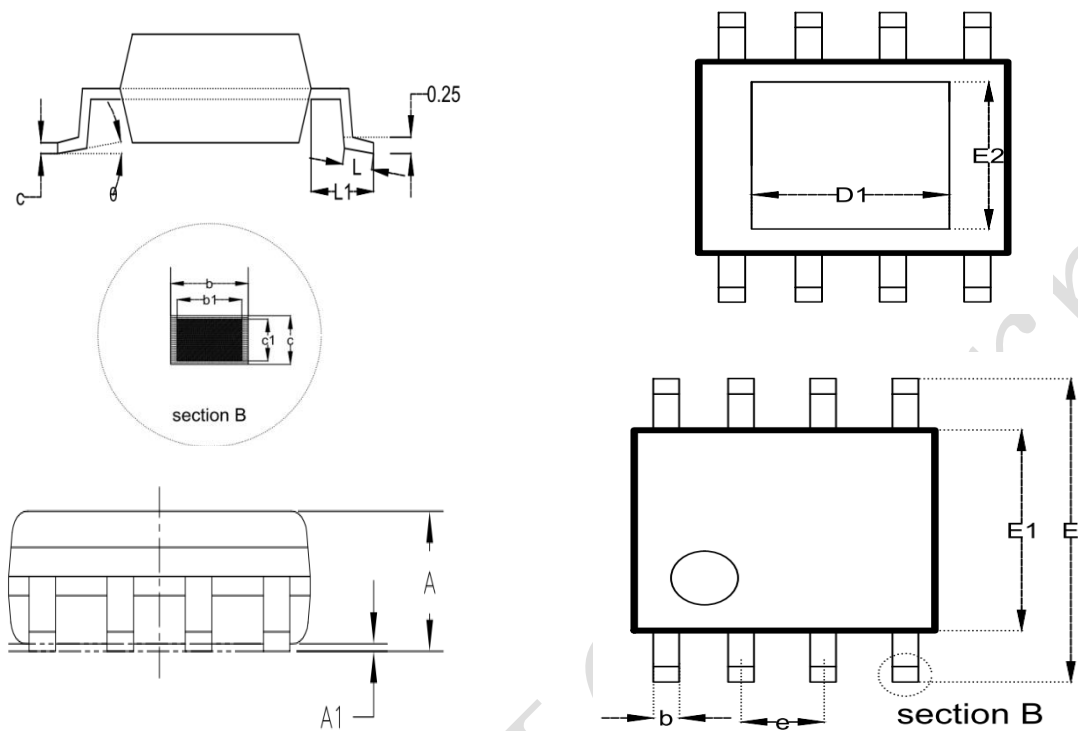

SYMBOL	MILLIMETER		
	MIN	NOM	MAX
A	--	--	1.65
A1	0.05	--	0.15
A	1.30	1.40	1.50
A3	0.60	0.65	0.70
b	0.39	--	0.48
b1	0.38	0.41	0.43
c	0.21	--	0.25
c1	0.19	0.20	0.21
D	4.70	4.90	5.10
E	5.80	6.00	6.20
E1	3.70	3.90	4.10
e	1.27BSC		
h	0.25	--	0.50
L	0.50	0.60	0.80
L1	1.05BSC		
θ	0	--	8°
D1	--	2.09	--
E2	--	2.09	--

IMPORTANT NOTICE

INJOINIC TECHNOLOGY and its subsidiaries reserve the right to make corrections, enhancements, improvements and other changes to its semiconductor products and services. Buyers should obtain the latest relevant information before placing orders and should verify that such information is current and complete. All semiconductor products (also referred to herein as “components”) are sold subject to INJOINIC TECHNOLOGY's terms and conditions of sale supplied at the time of order acknowledgment.

INJOINIC TECHNOLOGY assumes no liability for applications assistance or the design of Buyers' products. Buyers are responsible for their products and applications using INJOINIC TECHNOLOGY's components. To minimize the risks associated with Buyers' products and applications, Buyers should provide adequate design and operating safeguards.

Buyer acknowledges and agrees that it is solely responsible for compliance with all legal, regulatory and safety-related requirements concerning its products, and any use of INJOINIC TECHNOLOGY's components in its applications, notwithstanding any applications-related information or support that may be provided by INJOINIC TECHNOLOGY. Buyer represents and agrees that it has all the necessary expertise to create and implement safeguards which anticipate dangerous consequences of failures, monitor failures and their consequences, lessen the likelihood of failures that might cause harm and take appropriate remedial actions. Buyer will fully indemnify INJOINIC TECHNOLOGY and its representatives against any damages arising out of the use of any INJOINIC TECHNOLOGY's components in safety-critical applications.

Reproduction of significant portions of INJOINIC TECHNOLOGY's information in INJOINIC TECHNOLOGY's data books or data sheets is permissible only if reproduction is without alteration and is accompanied by all associated warranties, conditions, limitations, and notices. INJOINIC TECHNOLOGY is not responsible or liable for such altered documentation. Information of third parties may be subject to additional restrictions.

INJOINIC TECHNOLOGY will update this document from time to time. The actual parameters of the product may vary due to different models or other items. This document voids all express and any implied warranties.

Resale of INJOINIC TECHNOLOGY's components or services with statements different from or beyond the parameters stated by INJOINIC TECHNOLOGY for that component or service voids all express and any implied warranties for the associated INJOINIC TECHNOLOGY's component or service and is an unfair and deceptive business practice. INJOINIC TECHNOLOGY is not responsible or liable for any such statements.