

## Part No.: JSL-502WWC

### Features:

- Single color
- High bright output
- Low power consumption
- High reliability and long life

### Descriptions:

- Dice material: AlGaInP
- Emitting Color: Super Bright Warm White
- Device Outline:  $\phi$  5mm Round Type
- Lens Type: Water Clear

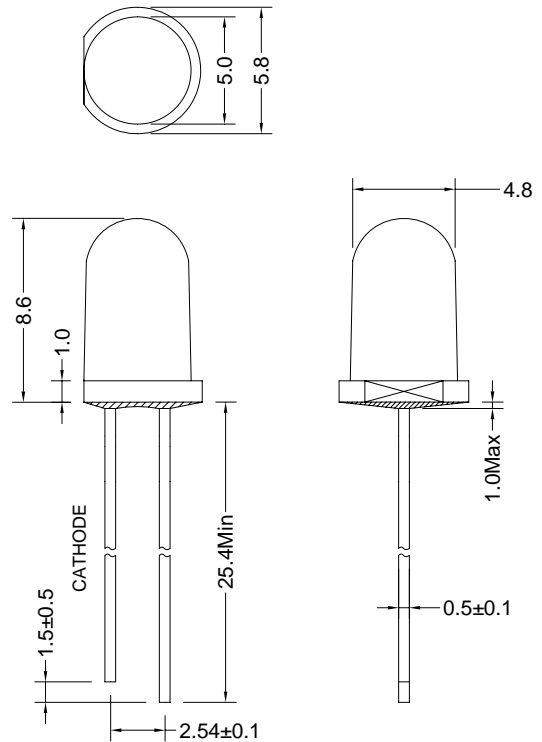

1. All dimensions are millimeters
2. Tolerance is  $\pm 0.20$ mm unless otherwise noted

### Directivity:

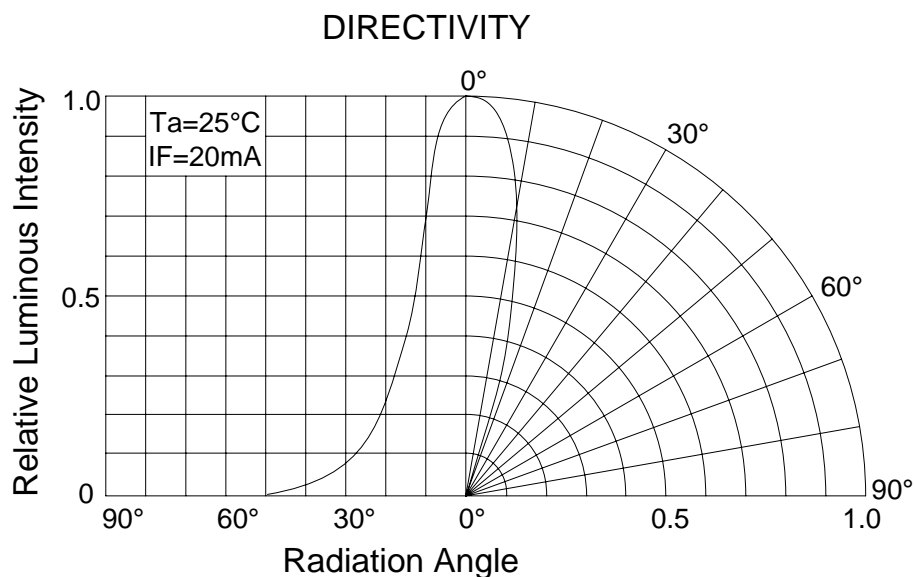



# Ningbo Junsheng Electronics Co.,LTD.

Part No.: **JSL-502WWC**

## Absolute maximum ratings (Ta = 25°C)

Parameter	Symbol	Test Condition	Values		Unit
			Min.	Max.	
Reverse Voltage	V <sub>R</sub>	I <sub>R</sub> = 30 μ A	5	--	V
Forward Current	I <sub>F</sub>	----	----	30	mA
Power Dissipation	P <sub>d</sub>	----	----	75	mW
Pulse Current	I <sub>peak</sub>	Duty=0.1mS, 1kHz	----	100	mA
Operating Temperature	T <sub>opr</sub>	----	-40	+85	°C
Storage Temperature	T <sub>str</sub>	----	-40	+100	°C

## Electrical and optical characteristics (Ta = 25°C)

Parameter	Symbol	Test Condition	Values			Unit
			Min.	Typ.	Max.	
Forward Voltage 正向电压	V <sub>F</sub>	I <sub>F</sub> =20mA	----	3.2	3.6	V
Reverse Current	I <sub>R</sub>	V <sub>R</sub> =5V	----	----	30	μ A
Color Temperature	T <sub>c</sub>	I <sub>F</sub> = 20mA	—	3000	—	K
Luminous Intensity	I <sub>v</sub>	I <sub>F</sub> =20mA	----	15000	22000	mcd
Viewing Angle	2 θ 1/2	I <sub>F</sub> =20mA	----	18	----	deg.

### Typical electrical/optical characteristic curves:

