



150 Dodd Street SE  
Marietta, GA. 30060

**Phone:** 770-973-6251  
**Fax:** 678-401-3854

**Email:** [info@mgs4u.com](mailto:info@mgs4u.com)  
**Website:** [www.mgs4u.com](http://www.mgs4u.com)

UHF male, Crimp-On, Cable End Connector for RG-11, RG-213, RG-213/U, RG-393, RG-393/U, RG-8, RG-8/U, RG-8A, RG-83, LMR-400, LMR-400 Ultraflex, Belden 7810A, Belden 8216, Belden 83269, Belden 83284, Belden 84316, and other 0.390 and 0.405 Inch OD Coax.



### Technical Data Sheet

This UHF Male Crimp Connector is one of several thousand RF products available from Max-Gain Systems, Inc. This connector has a crimp on interface with the coax selected.

This connector is made from a Solid Brass body that is precision machined and plated with Silver for superior performance and value. This UHF Male Crimp Connector has a PTFE dielectric and a silver plated brass center pin. The UHF Male interface (also known as a PL-259 connection) is by far the most popular connection type used in Amateur Radio. This RF connector fits (but not limited to) RG-11, RG-213, RG-213/U, RG-393, RG-393/U, RG-8, RG-8/U, RG-8A, RG-83, LMR-400, LMR-400 Ultraflex, Belden 7810A, Belden 8216, Belden 83269, Belden 83284, Belden 84316, and other 0.39 and 0.405 Inch OD Coax.

### Material Specifications

UHF male, Crimp-On, Cable End Connector for .405 Coax		Part Number 7505-UHF-400
Description	Material	Plating
Ferrule	Brass	Silver
Pin	Brass	Silver
Shell	Brass	Silver
Insulator	PTFE	White
Body	Brass	Silver

## Mechanical Specifications

Size	Dimension
Length	1.2 in (30.6 mm)
Width	0.72 in (18.2 mm)
Height	0.72 in (18.2 mm)
Weight	0.8 oz (24 g)

## Environmental Specifications

Temperature	Spec
Operating Range	-65 to +165 deg C

## Compliance Certifications (see product page for current documentation)

**Availability** Click the following link (or enter part number in the “SEARCH” bar at the top of any page of the website) to obtain additional part information including price, inventory and certifications: <https://mgs4u.com/product/uhf-male-crimp-connector-for-0-405-inch-od-coax-7505-uhf-400/>

5/8-24UNEF-2B

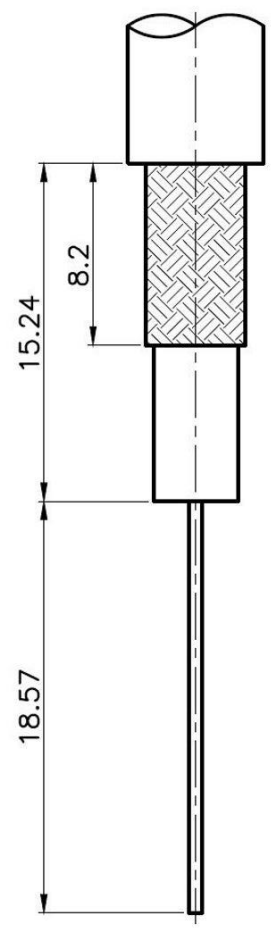
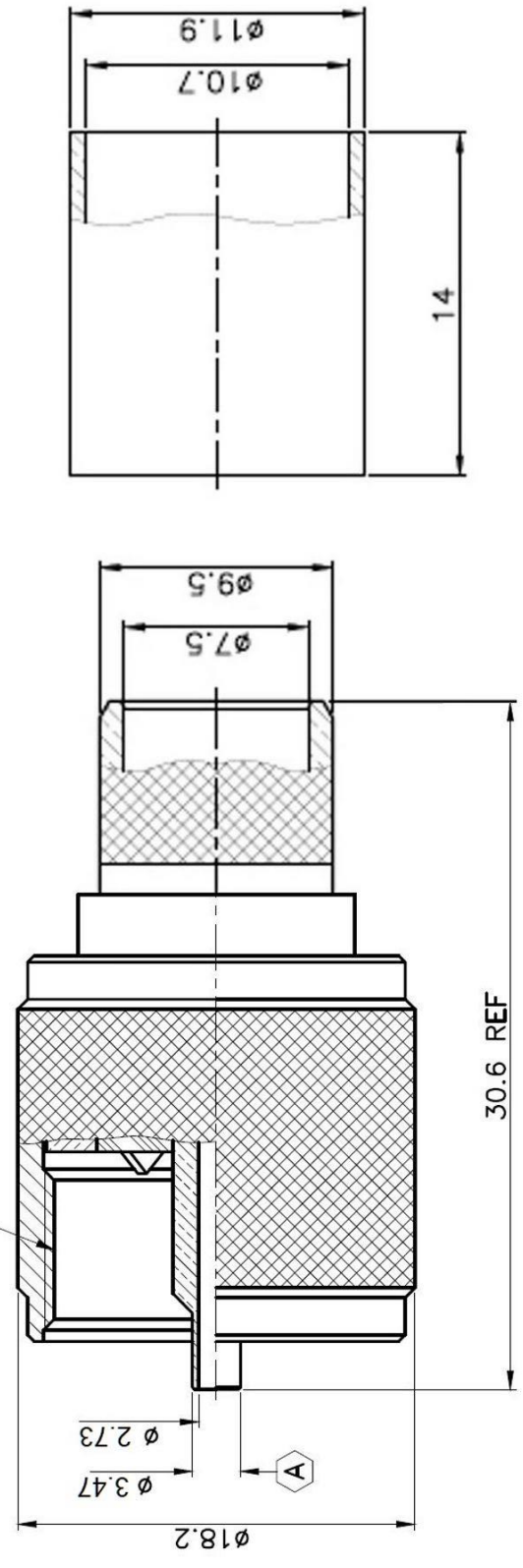

RECOMMENDED  
CABLE STRIPPING DIM'S



Max-Gain Systems, Inc.  
150 Dodd Street SE, Marietta, GA. 30060  
Phone: (770) 973-6251 | Fax: (678) 401-3854  
Website: www.mgs4u.com | E-Mail: sales@mgs4u.com

TITLE: UHF male Crimp Connector for  
0.405 Inch OD Coax  
DRAWING NO: 7505-UHF-400  
FILE NO :

		PART NO	DATE
		APPROVED	DATE
		CHECKED	DATE
		DRAWN	DATE
		UNLESS OTHERWISE SPECIFIED TOLERANCES 0.5-5 = ±0.2 5-30 = ±0.4 30-120 = ±0.6 120-315 = ±1 315-1000 = ±1.6 1000-2000 = ±2.4	
		UNIT: mm	
		SCALE: .	
NO.	DESCRIPTION	MATERIAL	QTY
	FERRULE	BRASS	
	SHELL	BRASS	SILVER
	PIN	BRASS	SILVER
	INSULATOR	TEFLON	WHITE
	BODY	BRASS	SILVER
			FINISH

.429"

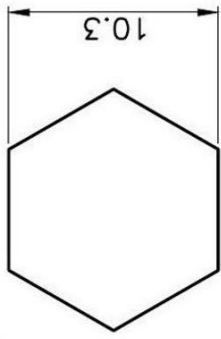

Die Size B

.128"



Die Size A

# Installation Guide

We will begin by installing the UHF male crimp-on connector on a piece of coax. This process is the same for all the types of coaxial cable that fit this UHF crimp-on connector. These connectors fit on a wide range of coax types, including: RG-11, RG-213, RG-213/U, RG-393, RG-393/U, RG-8, RG-8/U, RG-8A, RG-83, LMR-400, LMR-400 Ultraflex, Belden 7810A, Belden 8216, Belden 83269, Belden 83284, Belden 84316, and other 0.39 and 0.405 Inch OD Coax.

## Identify all connector parts (2 Parts):

Each connector consists of one body assembly (plug) and one rear ferrule (crimp sleeve),

### Step 1

CRIMP SLEEVE

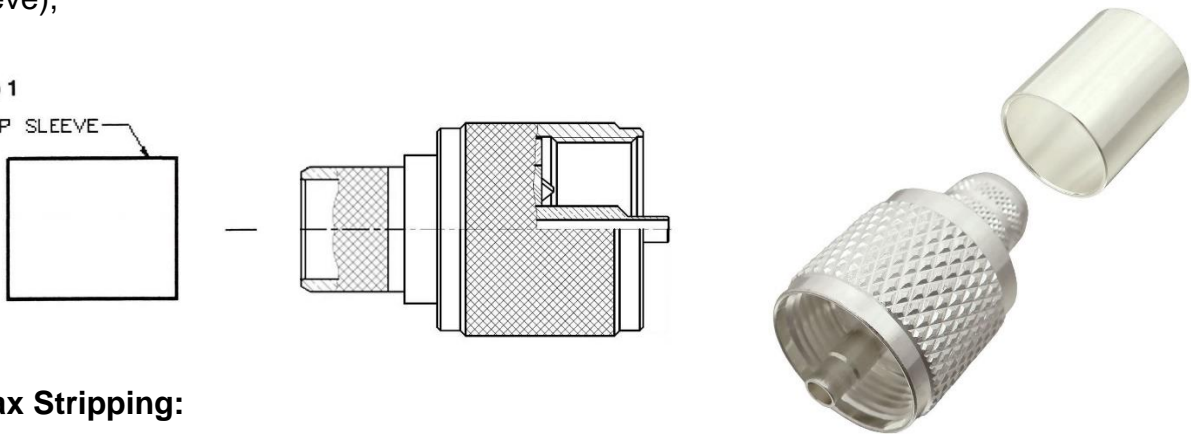

## Coax Stripping:

First cut your coaxial cable to the desired length and then strip the black jacket back approximately 33.81mm (1.33"). When the jacket is stripped cut the braid/foil back 25.61mm (1.00") from the fresh cut end. Finally, cut back the dielectric 18.57mm (0.73") from the fresh end down to the center conductor. The braid needs to be cut back further than the dielectric to insure that none of the braid or foil is touching the center conductor which could cause a short.

Once the cable is prepped, **make sure to put the ferrule (crimp sleeve) of the connector on the coaxial cable BEFORE you proceed.**

### Step 2

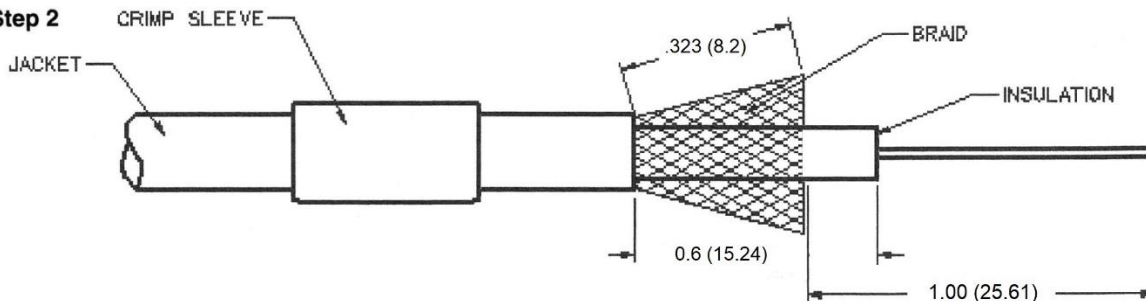

## Crimping and Soldering Install:

### Soldering Guide (preferred):

*This soldering guide is for soldering Max-Gain Systems, Inc. UHF crimp-on connectors. These are approximate measurements for our UHF crimp-on connectors, which adhere to industry standards for this type connector. If you choose to use this guide for connectors sold by others who do NOT adhere to these standards, the measurements could be off and result in a poor installation.*

**Now we begin by placing the body of the connector onto the end of the coax.** Be sure the center conductor goes through the center pin of the connector AND that the braid goes over the knurled section of the connector body. The braid needs to be on the outside of the connector and not tucked under it. This could lead to a short. Trim the excess center conductor with a small pair of diagonal cutters flush with the end of the center pin. Apply heat to the center pin of the UHF connector by placing your soldering iron underneath the pin. Before proceeding, allow sufficient time for the soldering iron tip to reach full operating temperature and clean the tip of the iron by wiping it with a damp sponge. Now apply the solder to the hole tip. The heat rises and heats up the pin faster than positioning the iron above the pin. When the pin is heated the solder will start to flow into the pin. It only takes a little solder to make a good connection. You can apply the solder so that it forms a small bubble / dome on the end of the center pin, but not more than that.

### Crimping Guide:

The center pin is crimpable by using the 0.128" hex die from your 7505-DIE-400 ratcheting crimper die to crimp the smaller tapered portion of the center pin. This crimp die is available by itself or as a kit with a ratcheting crimp handle.

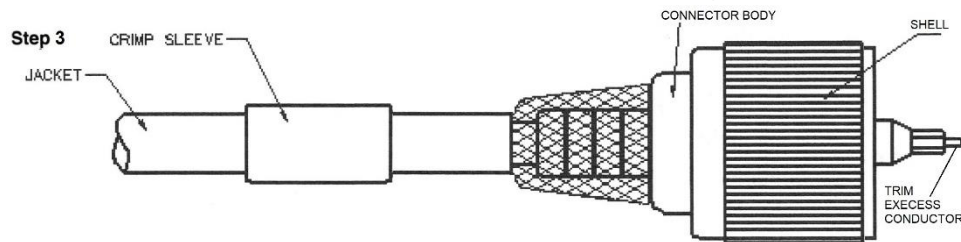

DIE Only	Die and Tool Kit
P/N: 7505-DIE-400	P/N: 7505-HANDLE-400
	

### **Crimping The Ferrule:**

Slide the ferrule (placed on the coax at the beginning of Step 2) over the braid and completely up against the connector body. Using the 0.429 hex of the 7505-DIE-400 installed into the 7505-HANDLE ratcheting crimp handle, crimp the ferrule at the location shown in the picture below (on the ferrule, but right up against the main body of the connector).

Step 4

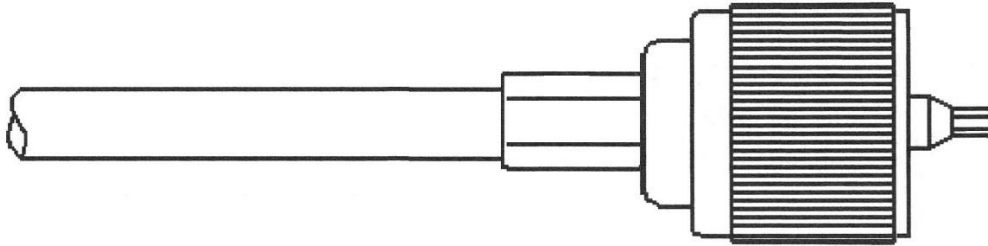

### **Final Testing:**

When this is completed, as a final test, you should always check resistance from the center pin to the body with an ohmmeter in a low resistance scale. After verifying that there are no braid – to – center pin shorts on the other end of the coaxial cable, you should see infinite resistance (open). This completes your UHF male crimp-on connector installation, and the connector is ready for use!