

ESP32-C3-MINI-1

ESP32-C3-MINI-1U

Datasheet

Small-sized 2.4 GHz Wi-Fi (802.11 b/g/n) and Bluetooth® 5 module
Built around ESP32-C3 series of SoCs, RISC-V single-core microprocessor
4 MB flash in chip package
15 GPIOs
On-board PCB antenna or external antenna connector



Version 1.0
Espressif Systems
Copyright © 2021

1 Module Overview

Note:

Check the link or the QR code to make sure that you use the latest version of this document:

https://espressif.com/sites/default/files/documentation/esp32-c3-mini-1_datasheet_en.pdf



1.1 Features

CPU and On-Chip Memory

- ESP32-C3FH4 or ESP32-C3FN4 embedded, 32-bit RISC-V single-core processor, up to 160 MHz
- 384 KB ROM
- 400 KB SRAM (16 KB for cache)
- 8 KB SRAM in RTC
- 4 MB embedded flash

Wi-Fi

- IEEE 802.11 b/g/n-compliant
- Center frequency range of operating channel: 2412 ~ 2484 MHz
- Supports 20 MHz, 40 MHz bandwidth in 2.4 GHz band
- 1T1R mode with data rate up to 150 Mbps
- Wi-Fi Multimedia (WMM)
- TX/RX A-MPDU, TX/RX A-MSDU
- Immediate Block ACK
- Fragmentation and defragmentation
- Transmit opportunity (TXOP)
- Automatic Beacon monitoring (hardware TSF)
- 4 × virtual Wi-Fi interfaces
- Simultaneous support for Infrastructure BSS in Station mode, SoftAP mode, Station + SoftAP mode, and promiscuous mode

Note that when ESP32-C3 series scans in Station mode, the SoftAP channel will change along with

the Station channel

- Antenna diversity
- 802.11mc FTM

Bluetooth®

- Bluetooth LE: Bluetooth 5, Bluetooth mesh
- Speed: 125 Kbps, 500 Kbps, 1 Mbps, 2 Mbps
- Advertising extensions
- Multiple advertisement sets
- Channel selection algorithm #2

Peripherals

- GPIO, SPI, UART, I2C, I2S, remote control peripheral, LED PWM controller, general DMA controller, TWAI® controller (compatible with ISO 11898-1), USB Serial/JTAG controller, temperature sensor, SAR ADC

Integrated Components on Module

- 40 MHz crystal oscillator

Antenna Options

- On-board PCB antenna (ESP32-C3-MINI-1)
- External antenna via a connector (ESP32-C3-MINI-1U)

Operating Conditions

- Operating voltage/Power supply: 3.0 ~ 3.6 V
- Operating ambient temperature:

- 85 °C version module: –40 ~ 85 °C
- 105 °C version module: –40 ~ 105 °C
- Green certification: RoHS/REACH

Certification

- RF certification: FCC/CE/SRRC

Test

- HTOL/HTSL/uHAST/TCT/ESD/Latch-up

1.2 Description

ESP32-C3-MINI-1 and ESP32-C3-MINI-1U are two general-purpose Wi-Fi and Bluetooth LE modules. The rich set of peripherals and a small size make the two modules an ideal choice for smart homes, industrial automation, health care, consumer electronics, etc.

The ordering information for the two modules is as follows:

Table 2: Ordering Information

Module	Ordering code	Chip embedded	Module dimensions (mm)
ESP32-C3-MINI-1 (85 °C version)	ESP32-C3-MINI-1-N4	ESP32-C3FN4	13.2 × 16.6 × 2.4
ESP32-C3-MINI-1 (105 °C version)	ESP32-C3-MINI-1-H4	ESP32-C3FH4	
ESP32-C3-MINI-1U (85 °C version)	ESP32-C3-MINI-1U-N4	ESP32-C3FN4	13.2 × 12.5 × 2.4
ESP32-C3-MINI-1U (105 °C version)	ESP32-C3-MINI-1U-H4	ESP32-C3FH4	

ESP32-C3-MINI-1 comes with a PCB antenna. ESP32-C3-MINI-1U comes with a connector for an external antenna. ESP32-C3-MINI-1 and ESP32-C3-MINI-1U have two variants:

- 85 °C version integrating the ESP32-C3FN4 chip and operating at –40 ~ 85 °C
- 105 °C version integrating the ESP32-C3FH4 chip and operating at –40 ~ 105 °C

The two variants only differ in chip integrated and ambient operating temperature. In this datasheet unless otherwise stated, ESP32-C3-MINI-1 refers to both ESP32-C3-MINI-1-N4 and ESP32-C3-MINI-1-H4, whereas ESP32-C3-MINI-1U refers to both ESP32-C3-MINI-1U-N4 and ESP32-C3-MINI-1U-H4.

The ESP32-C3FN4 chip and the ESP32-C3FH4 chip, both with a 4 MB flash, fall into the same category, namely ESP32-C3 chip series. ESP32-C3 series of chips have a 32-bit RISC-V single-core processor. They integrate a rich set of peripherals, ranging from UART, I2C, I2S, remote control peripheral, LED PWM controller, general DMA controller, TWAI® controller, USB Serial/JTAG controller, temperature sensor, and ADC. It also includes SPI, Dual SPI and Quad SPI interfaces.

The ESP32-C3FN4 chip and the ESP32-C3FH4 chip vary only in the ambient temperature. For details, please refer to *Family Member Comparison* in [ESP32-C3 Series Datasheet](#).

1.3 Applications

- [Smart Home](#)
 - Light control
 - Smart button
 - Smart plug
 - Indoor positioning
- [Industrial Automation](#)
 - Industrial robot
 - Mesh network
 - Human machine interface (HMI)
 - Industrial field bus
- [Health Care](#)
 - Health monitor
 - Baby monitor
- [Consumer Electronics](#)
 - Smart watch and bracelet
 - Over-the-top (OTT) devices
- Wi-Fi and bluetooth speaker
- Logger toys and proximity sensing toys
- Smart Agriculture
 - Smart greenhouse
 - Smart irrigation
 - Agriculture robot
- Retail and Catering
 - POS machines
 - Service robot
- Audio Device
 - Internet music players
 - Live streaming devices
 - Internet radio players
- Generic Low-power IoT Sensor Hubs
- Generic Low-power IoT Data Loggers

Contents

1	Module Overview	2
1.1	Features	2
1.2	Description	3
1.3	Applications	4
2	Block Diagram	8
3	Pin Definitions	9
3.1	Pin Layout	9
3.2	Pin Description	9
3.3	Strapping Pins	10
4	Electrical Characteristics	13
4.1	Absolute Maximum Ratings	13
4.2	Recommended Operating Conditions	13
4.3	DC Characteristics (3.3 V, 25 °C)	13
4.4	Current Consumption Characteristics	14
4.5	Wi-Fi Radio	15
4.5.1	Wi-Fi RF Standards	15
4.5.2	Wi-Fi RF Transmitter (TX) Specifications	15
4.5.3	Wi-Fi RF Receiver (RX) Specifications	16
4.6	Bluetooth LE Radio	17
4.6.1	Bluetooth LE RF Transmitter (TX) Specifications	17
4.6.2	Bluetooth LE RF Receiver (RX) Specifications	19
5	Module Schematics	22
6	Peripheral Schematics	24
7	Physical Dimensions and PCB Land Pattern	25
7.1	Physical Dimensions	25
7.2	Recommended PCB Land Pattern	26
7.3	Dimensions of External Antenna Connector	28
8	Product Handling	29
8.1	Storage Conditions	29
8.2	Electrostatic Discharge (ESD)	29
8.3	Reflow Profile	29
9	Related Documentation and Resources	30
	Revision History	31

List of Tables

2	Ordering Information	3
3	Pin Definitions	9
4	Strapping Pins	11
5	Parameter Descriptions of Setup and Hold Times for the Strapping Pin	12
6	Absolute Maximum Ratings	13
7	Recommended Operating Conditions	13
8	DC Characteristics (3.3 V, 25 °C)	13
9	Current Consumption Depending on RF Modes	14
10	Current Consumption Depending on Work Modes	14
11	Wi-Fi RF Standards	15
12	TX Power with Spectral Mask and EVM Meeting 802.11 Standards	15
13	TX EVM Test	15
14	RX Sensitivity	16
15	Maximum RX Level	17
16	RX Adjacent Channel Rejection	17
17	Transmitter General Characteristics	17
18	Transmitter Characteristics - Bluetooth LE 1 Mbps	18
19	Transmitter Characteristics - Bluetooth LE 2 Mbps	18
20	Transmitter Characteristics - Bluetooth LE 125 Kbps	18
21	Transmitter Characteristics - Bluetooth LE 500 Kbps	19
22	Receiver Characteristics - Bluetooth LE 1 Mbps	19
23	Receiver Characteristics - Bluetooth LE 2 Mbps	20
24	Receiver Characteristics - Bluetooth LE 125 Kbps	20
25	Receiver Characteristics - Bluetooth LE 500 Kbps	20

List of Figures

1	ESP32-C3-MINI-1 Block Diagram	8
2	ESP32-C3-MINI-1U Block Diagram	8
3	Pin Layout (Top View)	9
4	Setup and Hold Times for the Strapping Pin	12
5	ESP32-C3-MINI-1 Schematics	22
6	ESP32-C3-MINI-1U Schematics	23
7	Peripheral Schematics	24
8	ESP32-C3-MINI-1 Physical Dimensions	25
9	ESP32-C3-MINI-1U Physical Dimensions	25
10	ESP32-C3-MINI-1 Recommended PCB Land Pattern	26
11	ESP32-C3-MINI-1U Recommended PCB Land Pattern	27
12	Dimensions of External Antenna Connector	28
13	Reflow Profile	29

2 Block Diagram

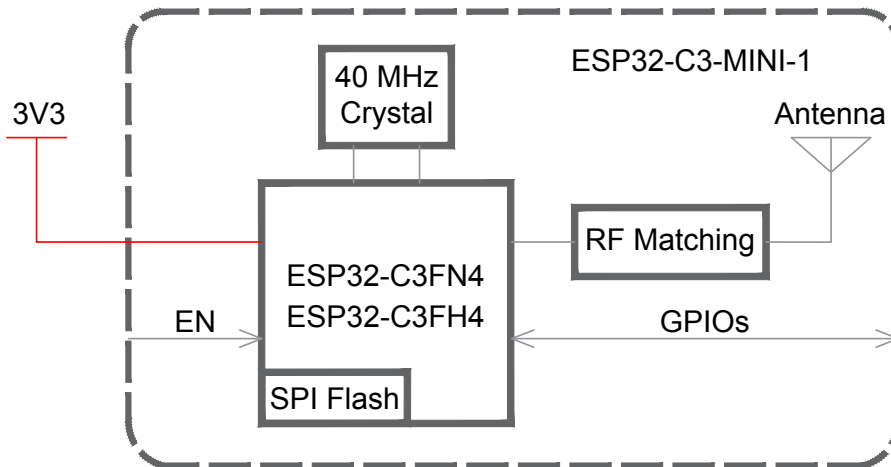

Figure 1: ESP32-C3-MINI-1 Block Diagram

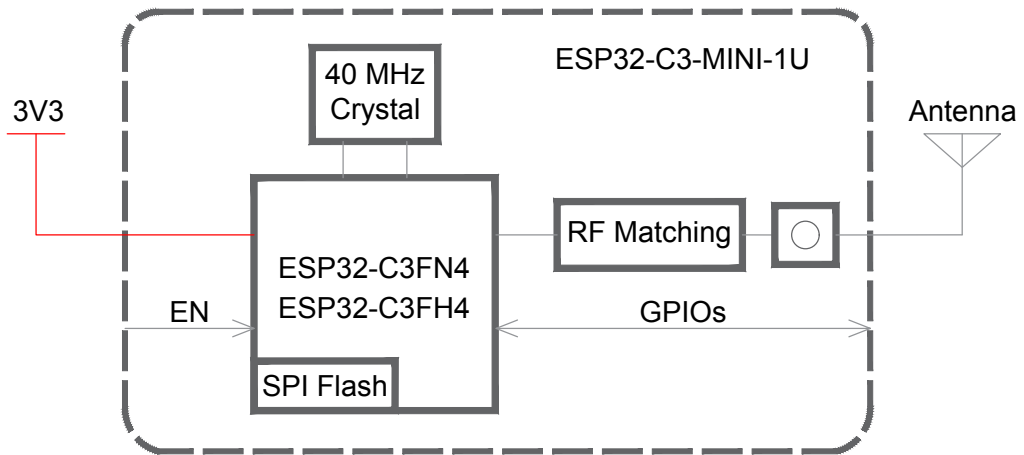

Figure 2: ESP32-C3-MINI-1U Block Diagram

3 Pin Definitions

3.1 Pin Layout

The pin diagram below shows the approximate location of pins on the module. For the actual diagram drawn to scale, please refer to Figure 7.1 *Physical Dimensions*.

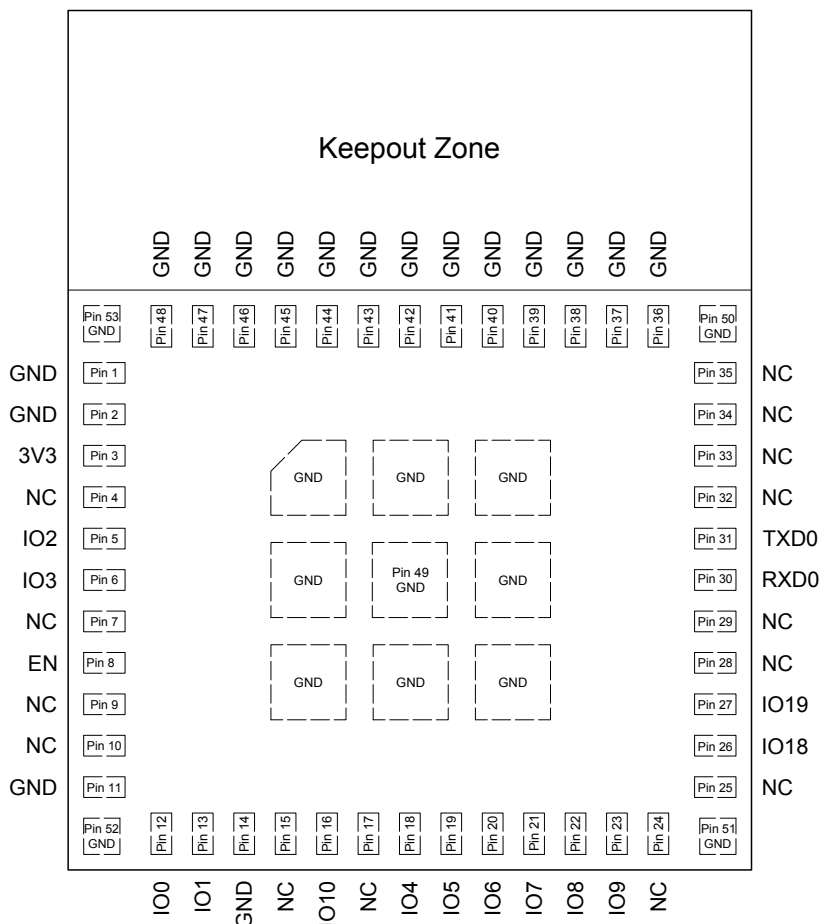

Figure 3: Pin Layout (Top View)

3.2 Pin Description

The module has 53 pins. See pin definitions in Table 3.

For peripheral pin configurations, please refer to [ESP32-C3 Series Datasheet](#).

Table 3: Pin Definitions

Name	No.	Type ¹	Function
GND	1, 2, 11, 14, 36-53	P	Ground
3V3	3	P	Power supply

Cont'd on next page

Table 3 – cont'd from previous page

Name	No.	Type ¹	Function
NC	4, 7, 9, 10, 15, 17, 24, 25, 28, 29, 32-35	—	NC
IO2	5	I/O/T	GPIO2, ADC1_CH2, FSPIQ
IO3	6	I/O/T	GPIO3, ADC1_CH3
EN	8	I	High: on, enables the chip. Low: off, the chip powers off. Note: Do not leave the EN pin floating.
IO0	12	I/O/T	GPIO0, ADC1_CH0, XTAL_32K_P
IO1	13	I/O/T	GPIO1, ADC1_CH1, XTAL_32K_N
IO10	16	I/O/T	GPIO10, FSPICS0
IO4	18	I/O/T	GPIO4, ADC1_CH4, FSPIHD, MTMS
IO5	19	I/O/T	GPIO5, ADC2_CH0, FSPIWP, MTDI
IO6	20	I/O/T	GPIO6, FSPICK, MTCK
IO7	21	I/O/T	GPIO7, FSPID, MTDO
IO8	22	I/O/T	GPIO8
IO9	23	I/O/T	GPIO9
IO18	26	I/O/T	GPIO18, USB_D-
IO19	27	I/O/T	GPIO19, USB_D+
RXD0	30	I/O/T	GPIO20, U0RXD
TXD0	31	I/O/T	GPIO21, U0TXD

¹ P: power supply; I: input; O: output; T: high impedance.

3.3 Strapping Pins

Note:

The content below is excerpted from Section Strapping Pins in [ESP32-C3 Series Datasheet](#). For the strapping pin mapping between the chip and modules, please refer to Chapter 5 [Module Schematics](#).

ESP32-C3 family has three strapping pins:

- GPIO2
- GPIO8
- GPIO9

Software can read the values of GPIO2, GPIO8 and GPIO9 from GPIO_STRAPPING field in GPIO_STRAP_REG register. For register description, please refer to Section GPIO Matrix Register Summary in [ESP32-C3 Technical Reference Manual](#).

During the chip's system reset, the latches of the strapping pins sample the voltage level as strapping bits of "0" or "1", and hold these bits until the chip is powered down or shut down.

Types of system reset include:

- power-on-reset
- RTC watchdog reset
- brownout reset
- analog super watchdog reset
- crystal clock glitch detection reset

By default, GPIO9 is connected to the internal pull-up resistor. If GPIO9 is not connected or connected to an external high-impedance circuit, the latched bit value will be "1"

To change the strapping bit values, you can apply the external pull-down/pull-up resistances, or use the host MCU's GPIOs to control the voltage level of these pins when powering on ESP32-C3 family.

After reset, the strapping pins work as normal-function pins.

Refer to Table 4 for a detailed boot-mode configuration of the strapping pins.

Table 4: Strapping Pins

Booting Mode ¹			
Pin	Default	SPI Boot	Download Boot
GPIO2	N/A	1	1
GPIO8	N/A	Don't care	1
GPIO9	Internal pull-up	1	0
Enabling/Disabling ROM Code Print During Booting			
Pin	Default	Functionality	
GPIO8	N/A	When the value of eFuse field EFUSE_UART_PRINT_CONTROL is 0 (default), print is enabled and not controlled by GPIO8. 1, if GPIO8 is 0, print is enabled; if GPIO8 is 1, it is disabled. 2, if GPIO8 is 0, print is disabled; if GPIO8 is 1, it is enabled. 3, print is disabled and not controlled by GPIO8.	

¹ The strapping combination of GPIO8 = 0 and GPIO9 = 0 is invalid and will trigger unexpected behavior.

Figure 4 shows the setup and hold times for the strapping pin before and after the CHIP_EN signal goes high. Details about the parameters are listed in Table 5.

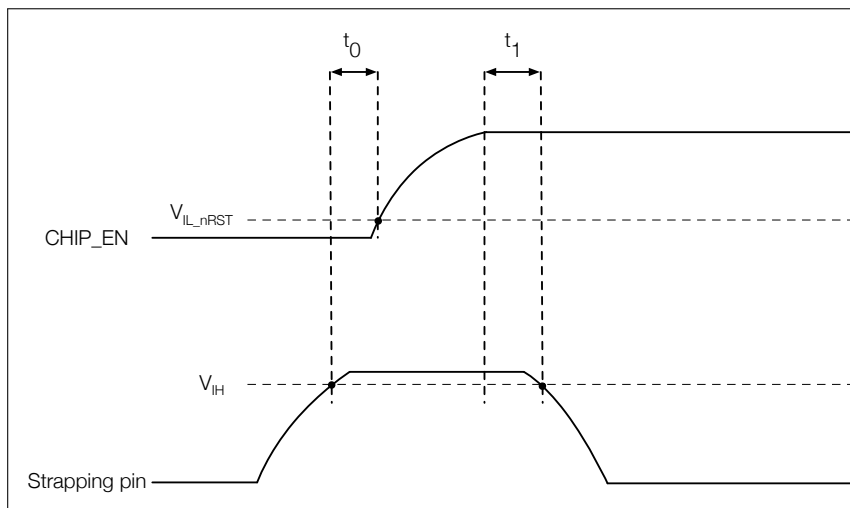

Figure 4: Setup and Hold Times for the Strapping Pin

Table 5: Parameter Descriptions of Setup and Hold Times for the Strapping Pin

Parameter	Description	Min (ms)
t_0	Setup time before CHIP_EN goes from low to high	0
t_1	Hold time after CHIP_EN goes high	3

4 Electrical Characteristics

4.1 Absolute Maximum Ratings

Stresses above those listed in *Absolute Maximum Ratings* may cause permanent damage to the device. These are stress ratings only and functional operation of the device at these or any other conditions beyond those indicated under *Recommended Operating Conditions* is not implied. Exposure to absolute-maximum-rated conditions for extended periods may affect device reliability.

Table 6: Absolute Maximum Ratings

Symbol	Parameter	Min	Max	Unit
VDD33	Power supply voltage	-0.3	3.6	V
T _{STORE}	Storage temperature	-40	105	°C

4.2 Recommended Operating Conditions

Table 7: Recommended Operating Conditions

Symbol	Parameter	Min	Typ	Max	Unit
VDD33	Power supply voltage	3.0	3.3	3.6	V
I _{VDD}	Current delivered by external power supply	0.5	—	—	A
T _A	Operating ambient temperature	85 °C version	—	85	°C
		105 °C version		105	
Humidity	Humidity condition	—	—	85	%RH

4.3 DC Characteristics (3.3 V, 25 °C)

Table 8: DC Characteristics (3.3 V, 25 °C)

Symbol	Parameter	Min	Typ	Max	Unit
C _{IN}	Pin capacitance	—	2	—	pF
V _{IH}	High-level input voltage	0.75 × VDD ¹	—	VDD ¹ + 0.3	V
V _{IL}	Low-level input voltage	-0.3	—	0.25 × VDD ¹	V
I _{IH}	High-level input current	—	—	50	nA
I _{IL}	Low-level input current	—	—	50	nA
V _{OH} ²	High-level output voltage	0.8 × VDD ¹	—	—	V
V _{OL} ²	Low-level output voltage	—	—	0.1 × VDD ¹	V
I _{OH}	High-level source current (VDD ¹ = 3.3 V, V _{OH} ≥ 2.64 V, PAD_DRIVER = 3)	—	40	—	mA
I _{OL}	Low-level sink current (VDD ¹ = 3.3 V, V _{OL} = 0.495 V, PAD_DRIVER = 3)	—	28	—	mA
R _{PU}	Pull-up resistor	—	45	—	kΩ
R _{PD}	Pull-down resistor	—	45	—	kΩ
V _{IH_nRST}	Chip reset release voltage	0.75 × VDD ¹	—	VDD ¹ + 0.3	V

Cont'd on next page

Table 8 – cont'd from previous page

Symbol	Parameter	Min	Typ	Max	Unit
V_{IL_nRST}	Chip reset voltage	-0.3	—	$0.25 \times VDD^1$	V

¹ VDD is the I/O voltage for a particular power domain of pins.

² V_{OH} and V_{OL} are measured using high-impedance load.

4.4 Current Consumption Characteristics

With the use of advanced power-management technologies, the module can switch between different power modes. For details on different power modes, please refer to Section *Low Power Management* in [ESP32-C3 Series Datasheet](#).

Table 9: Current Consumption Depending on RF Modes

Work mode	Description		Peak (mA)
Active (RF working)	TX	802.11b, 1 Mbps, @21 dBm	350
		802.11g, 54 Mbps, @19 dBm	295
		802.11n, HT20, MCS 7, @18.5 dBm	290
		802.11n, HT40, MCS 7, @18.5 dBm	290
	RX	802.11b/g/n, HT20	82
		802.11n, HT40	84

¹ The current consumption measurements are taken with a 3.3 V supply at 25 °C of ambient temperature at the RF port. All transmitters' measurements are based on a 100% duty cycle.

² The current consumption figures for in RX mode are for cases when the peripherals are disabled and the CPU idle.

Table 10: Current Consumption Depending on Work Modes

Work mode	Description		Typ	Unit
Modem-sleep ^{1, 2}	The CPU is powered on ³	160 MHz	20	mA
		80 MHz	15	mA
Light-sleep	—		130	μ A
Deep-sleep	RTC timer + RTC memory		5	μ A
Power off	CHIP_PU is set to low level, the chip is powered off		1	μ A

¹ The current consumption figures in Modem-sleep mode are for cases where the CPU is powered on and the cache idle.

² When Wi-Fi is enabled, the chip may switch between Active and Modem-sleep modes. Therefore, current consumption changes accordingly.

³ In practice, software can adjust CPU's frequency according to CPU load to reduce current consumption.

4.5 Wi-Fi Radio

4.5.1 Wi-Fi RF Standards

Table 11: Wi-Fi RF Standards

Name		Description
Center frequency range of operating channel ¹		2412 ~ 2484 MHz
Wi-Fi wireless standard		IEEE 802.11b/g/n
Data rate	20 MHz	11b: 1, 2, 5.5 and 11 Mbps 11g: 6, 9, 12, 18, 24, 36, 48, 54 Mbps 11n: MCS0-7, 72.2 Mbps (Max)
	40 MHz	11n: MCS0-7, 150 Mbps (Max)
Antenna type		PCB antenna and IPEX antenna

¹ Device should operate in the center frequency range allocated by regional regulatory authorities. Target center frequency range is configurable by software.

4.5.2 Wi-Fi RF Transmitter (TX) Specifications

Target TX power is configurable based on device or certification requirements. The default characteristics are provided in Table 12.

Table 12: TX Power with Spectral Mask and EVM Meeting 802.11 Standards

Rate	Min (dBm)	Typ (dBm)	Max (dBm)
802.11b, 1 Mbps	—	20.5	—
802.11b, 11 Mbps	—	20.5	—
802.11g, 6 Mbps	—	20.0	—
802.11g, 54 Mbps	—	18.0	—
802.11n, HT20, MCS 0	—	19.0	—
802.11n, HT20, MCS 7	—	17.5	—
802.11n, HT40, MCS 0	—	18.5	—
802.11n, HT40, MCS 7	—	17.0	—

Table 13: TX EVM Test

Rate	Min (dB)	Typ (dB)	SL ¹ (dB)
802.11b, 1 Mbps, @21 dBm	—	-24.5	-10
802.11b, 11 Mbps, @21 dBm	—	-25.0	-10
802.11g, 6 Mbps, @21 dBm	—	-23.0	-5
802.11g, 54 Mbps, @19 dBm	—	-28.0	-25
802.11n, HT20, MCS 0, @20 dBm	—	-23.5	-5
802.11n, HT20, MCS 7, @18.5 dBm	—	-30.5	-27

Cont'd on next page

Table 13 – cont'd from previous page

Rate	Min (dB)	Typ (dB)	SL ¹ (dB)
802.11n, HT40, MCS 0, @20 dBm	—	-26.5	-5
802.11n, HT40, MCS 7, @18.5 dBm	—	-30.5	-27

¹ SL stands for standard limit value.

4.5.3 Wi-Fi RF Receiver (RX) Specifications

Table 14: RX Sensitivity

Rate	Min (dBm)	Typ (dBm)	Max (dBm)
802.11b, 1 Mbps	—	-98.0	—
802.11b, 2 Mbps	—	-96.0	—
802.11b, 5.5 Mbps	—	-93.0	—
802.11b, 11 Mbps	—	-88.6	—
802.11g, 6 Mbps	—	-92.8	—
802.11g, 9 Mbps	—	-91.8	—
802.11g, 12 Mbps	—	-90.8	—
802.11g, 18 Mbps	—	-88.4	—
802.11g, 24 Mbps	—	-85.4	—
802.11g, 36 Mbps	—	-82.0	—
802.11g, 48 Mbps	—	-77.8	—
802.11g, 54 Mbps	—	-76.2	—
802.11n, HT20, MCS 0	—	-92.6	—
802.11n, HT20, MCS 1	—	-90.6	—
802.11n, HT20, MCS 2	—	-88.0	—
802.11n, HT20, MCS 3	—	-84.8	—
802.11n, HT20, MCS 4	—	-81.6	—
802.11n, HT20, MCS 5	—	-77.4	—
802.11n, HT20, MCS 6	—	-75.6	—
802.11n, HT20, MCS 7	—	-74.4	—
802.11n, HT40, MCS 0	—	-90.0	—
802.11n, HT40, MCS 1	—	-87.6	—
802.11n, HT40, MCS 2	—	-84.8	—
802.11n, HT40, MCS 3	—	-81.8	—
802.11n, HT40, MCS 4	—	-78.4	—
802.11n, HT40, MCS 5	—	-74.2	—
802.11n, HT40, MCS 6	—	-72.6	—
802.11n, HT40, MCS 7	—	-71.2	—

Table 15: Maximum RX Level

Rate	Min (dBm)	Typ (dBm)	Max (dBm)
802.11b, 1 Mbps	—	5	—
802.11b, 11 Mbps	—	5	—
802.11g, 6 Mbps	—	5	—
802.11g, 54 Mbps	—	0	—
802.11n, HT20, MCS 0	—	5	—
802.11n, HT20, MCS 7	—	0	—
802.11n, HT40, MCS 0	—	5	—
802.11n, HT40, MCS 7	—	0	—

Table 16: RX Adjacent Channel Rejection

Rate	Min (dB)	Typ (dB)	Max (dB)
802.11b, 1 Mbps	—	35	—
802.11b, 11 Mbps	—	35	—
802.11g, 6 Mbps	—	31	—
802.11g, 54 Mbps	—	14	—
802.11n, HT20, MCS 0	—	31	—
802.11n, HT20, MCS 7	—	13	—
802.11n, HT40, MCS 0	—	19	—
802.11n, HT40, MCS 7	—	8	—

4.6 Bluetooth LE Radio

4.6.1 Bluetooth LE RF Transmitter (TX) Specifications

Table 17: Transmitter General Characteristics

Parameter	Min	Typ	Max	Unit
RF transmit power	—	0	—	dBm
Gain control step	—	3	—	dB
RF power control range	-27	—	18	dBm

Table 18: Transmitter Characteristics - Bluetooth LE 1 Mbps

Parameter	Description	Min	Typ	Max	Unit
In-band emissions	$F = F_0 \pm 2$ MHz	—	-37.62	—	dBm
	$F = F_0 \pm 3$ MHz	—	-41.95	—	dBm
	$F = F_0 \pm > 3$ MHz	—	-44.48	—	dBm
Modulation characteristics	$\Delta f_{1_{avg}}$	—	245.00	—	kHz
	$\Delta f_{2_{max}}$	—	208.00	—	kHz
	$\Delta f_{2_{avg}}/\Delta f_{1_{avg}}$	—	0.93	—	—
Carrier frequency offset	—	—	-9.00	—	kHz
Carrier frequency drift	$ f_0 - f_n _{n=2, 3, 4, \dots, k}$	—	1.17	—	kHz
	$ f_1 - f_0 $	—	0.30	—	kHz
	$ f_n - f_{n-5} _{n=6, 7, 8, \dots, k}$	—	4.90	—	kHz

Table 19: Transmitter Characteristics - Bluetooth LE 2 Mbps

Parameter	Description	Min	Typ	Max	Unit
In-band emissions	$F = F_0 \pm 4$ MHz	—	-43.55	—	dBm
	$F = F_0 \pm 5$ MHz	—	-45.26	—	dBm
	$F = F_0 \pm > 5$ MHz	—	-47.00	—	dBm
Modulation characteristics	$\Delta f_{1_{avg}}$	—	497.00	—	kHz
	$\Delta f_{2_{max}}$	—	398.00	—	kHz
	$\Delta f_{2_{avg}}/\Delta f_{1_{avg}}$	—	0.95	—	—
Carrier frequency offset	—	—	-9.00	—	kHz
Carrier frequency drift	$ f_0 - f_n _{n=2, 3, 4, \dots, k}$	—	0.46	—	kHz
	$ f_1 - f_0 $	—	0.70	—	kHz
	$ f_n - f_{n-5} _{n=6, 7, 8, \dots, k}$	—	6.80	—	kHz

Table 20: Transmitter Characteristics - Bluetooth LE 125 Kbps

Parameter	Description	Min	Typ	Max	Unit
In-band emissions	$F = F_0 \pm 2$ MHz	—	-37.90	—	dBm
	$F = F_0 \pm 3$ MHz	—	-41.00	—	dBm
	$F = F_0 \pm > 3$ MHz	—	-42.50	—	dBm
Modulation characteristics	$\Delta f_{1_{avg}}$	—	252.00	—	kHz
	$\Delta f_{1_{max}}$	—	200.00	—	kHz
Carrier frequency offset	—	—	-13.70	—	kHz
Carrier frequency drift	$ f_0 - f_n _{n=1, 2, 3, \dots, k}$	—	1.52	—	kHz
	$ f_0 - f_3 $	—	0.65	—	kHz
	$ f_n - f_{n-3} _{n=7, 8, 9, \dots, k}$	—	0.70	—	kHz

Table 21: Transmitter Characteristics - Bluetooth LE 500 Kbps

Parameter	Description	Min	Typ	Max	Unit
In-band emissions	$F = F_0 \pm 2 \text{ MHz}$	—	-37.90	—	dBm
	$F = F_0 \pm 3 \text{ MHz}$	—	-41.30	—	dBm
	$F = F_0 \pm > 3 \text{ MHz}$	—	-42.80	—	dBm
Modulation characteristics	$\Delta f_{2\text{avg}}$	—	220.00	—	kHz
	$\Delta f_{2\text{max}}$	—	205.00	—	kHz
Carrier frequency offset	—	—	-11.90	—	kHz
Carrier frequency drift	$ f_0 - f_n _{n=1, 2, 3, \dots, k}$	—	1.37	—	kHz
	$ f_0 - f_3 $	—	1.09	—	kHz
	$ f_n - f_{n-3} _{n=7, 8, 9, \dots, k}$	—	0.51	—	kHz

4.6.2 Bluetooth LE RF Receiver (RX) Specifications

Table 22: Receiver Characteristics - Bluetooth LE 1 Mbps

Parameter	Description	Min	Typ	Max	Unit
Sensitivity @30.8% PER	—	—	-96	—	dBm
Maximum received signal @30.8% PER	—	—	10	—	dBm
Co-channel C/I	—	—	8	—	dB
Adjacent channel selectivity C/I	$F = F_0 + 1 \text{ MHz}$	—	-4	—	dB
	$F = F_0 - 1 \text{ MHz}$	—	-3	—	dB
	$F = F_0 + 2 \text{ MHz}$	—	-32	—	dB
	$F = F_0 - 2 \text{ MHz}$	—	-36	—	dB
	$F \geq F_0 + 3 \text{ MHz}^{(1)}$	—	—	—	dB
	$F \leq F_0 - 3 \text{ MHz}$	—	—	-39	—
Image frequency	—	—	-29	—	dB
Adjacent channel to image frequency	$F = F_{\text{image}} + 1 \text{ MHz}$	—	-38	—	dB
	$F = F_{\text{image}} - 1 \text{ MHz}$	—	-34	—	dB
Out-of-band blocking performance	30 MHz ~ 2000 MHz	—	-9	—	dBm
	2003 MHz ~ 2399 MHz	—	-18	—	dBm
	2484 MHz ~ 2997 MHz	—	-16	—	dBm
	3000 MHz ~ 12.75 GHz	—	-6	—	dBm
Intermodulation	—	—	-44	—	dBm

¹ Refer to the value of Adjacent channel to image frequency when $F = F_{\text{image}} - 1 \text{ MHz}$.

Table 23: Receiver Characteristics - Bluetooth LE 2 Mbps

Parameter	Description	Min	Typ	Max	Unit
Sensitivity @30.8% PER	—	—	-93	—	dBm
Maximum received signal @30.8% PER	—	—	0	—	dBm
Co-channel C/I	—	—	10	—	dB
Adjacent channel selectivity C/I	$F = F_0 + 2 \text{ MHz}$	—	-7	—	dB
	$F = F_0 - 2 \text{ MHz}$	—	-7	—	dB
	$F = F_0 + 4 \text{ MHz}^{(1)}$	—	—	—	dB
	$F = F_0 - 4 \text{ MHz}$	—	-34	—	dB
	$F \geq F_0 + 6 \text{ MHz}$	—	-39	—	dB
	$F \leq F_0 - 6 \text{ MHz}$	—	-39	—	dB
Image frequency	—	—	-27	—	dB
Adjacent channel to image frequency	$F = F_{image} + 2 \text{ MHz}$	—	-39	—	dB
	$F = F_{image} - 2 \text{ MHz}^{(2)}$	—	—	—	dB
Out-of-band blocking performance	30 MHz ~ 2000 MHz	—	-17	—	dBm
	2003 MHz ~ 2399 MHz	—	-19	—	dBm
	2484 MHz ~ 2997 MHz	—	-16	—	dBm
	3000 MHz ~ 12.75 GHz	—	-22	—	dBm
Intermodulation	—	—	-40	—	dBm

¹ Refer to the value of Image frequency.

² Refer to the value of Adjacent channel selectivity C/I when $F = F_0 + 2 \text{ MHz}$.

Table 24: Receiver Characteristics - Bluetooth LE 125 Kbps

Parameter	Description	Min	Typ	Max	Unit
Sensitivity @30.8% PER	—	—	-104	—	dBm
Maximum received signal @30.8% PER	—	—	10	—	dBm
Co-channel C/I	—	—	2	—	dB
Adjacent channel selectivity C/I	$F = F_0 + 1 \text{ MHz}$	—	-6	—	dB
	$F = F_0 - 1 \text{ MHz}$	—	-5	—	dB
	$F = F_0 + 2 \text{ MHz}$	—	-40	—	dB
	$F = F_0 - 2 \text{ MHz}$	—	-42	—	dB
	$F \geq F_0 + 3 \text{ MHz}^{(1)}$	—	—	—	dB
	$F \leq F_0 - 3 \text{ MHz}$	—	-46	—	dB
Image frequency	—	—	-34	—	dB
Adjacent channel to image frequency	$F = F_{image} + 1 \text{ MHz}$	—	-44	—	dB
	$F = F_{image} - 1 \text{ MHz}$	—	-37	—	dB

¹ Refer to the value of Adjacent channel to image frequency when $F = F_{image} - 1 \text{ MHz}$.

Table 25: Receiver Characteristics - Bluetooth LE 500 Kbps

Parameter	Description	Min	Typ	Max	Unit
Sensitivity @30.8% PER	—	—	-99	—	dBm

Cont'd on next page

Table 25 – cont'd from previous page

Parameter	Description	Min	Typ	Max	Unit
Maximum received signal @30.8% PER	—	—	10	—	dBm
Co-channel C/I	—	—	3	—	dB
Adjacent channel selectivity C/I	$F = F_0 + 1 \text{ MHz}$	—	-5	—	dB
	$F = F_0 - 1 \text{ MHz}$	—	-7	—	dB
	$F = F_0 + 2 \text{ MHz}$	—	-39	—	dB
	$F = F_0 - 2 \text{ MHz}$	—	-40	—	dB
	$F \geq F_0 + 3 \text{ MHz}^{(1)}$	—	—	—	dB
	$F \leq F_0 - 3 \text{ MHz}$	—	-40	—	dB
Image frequency	—	—	-34	—	dB
Adjacent channel to image frequency	$F = F_{image} + 1 \text{ MHz}$	—	-43	—	dB
	$F = F_{image} - 1 \text{ MHz}$	—	-38	—	dB

¹ Refer to the value of Adjacent channel to image frequency when $F = F_{image} - 1 \text{ MHz}$.

5 Module Schematics

This is the reference design of the module.

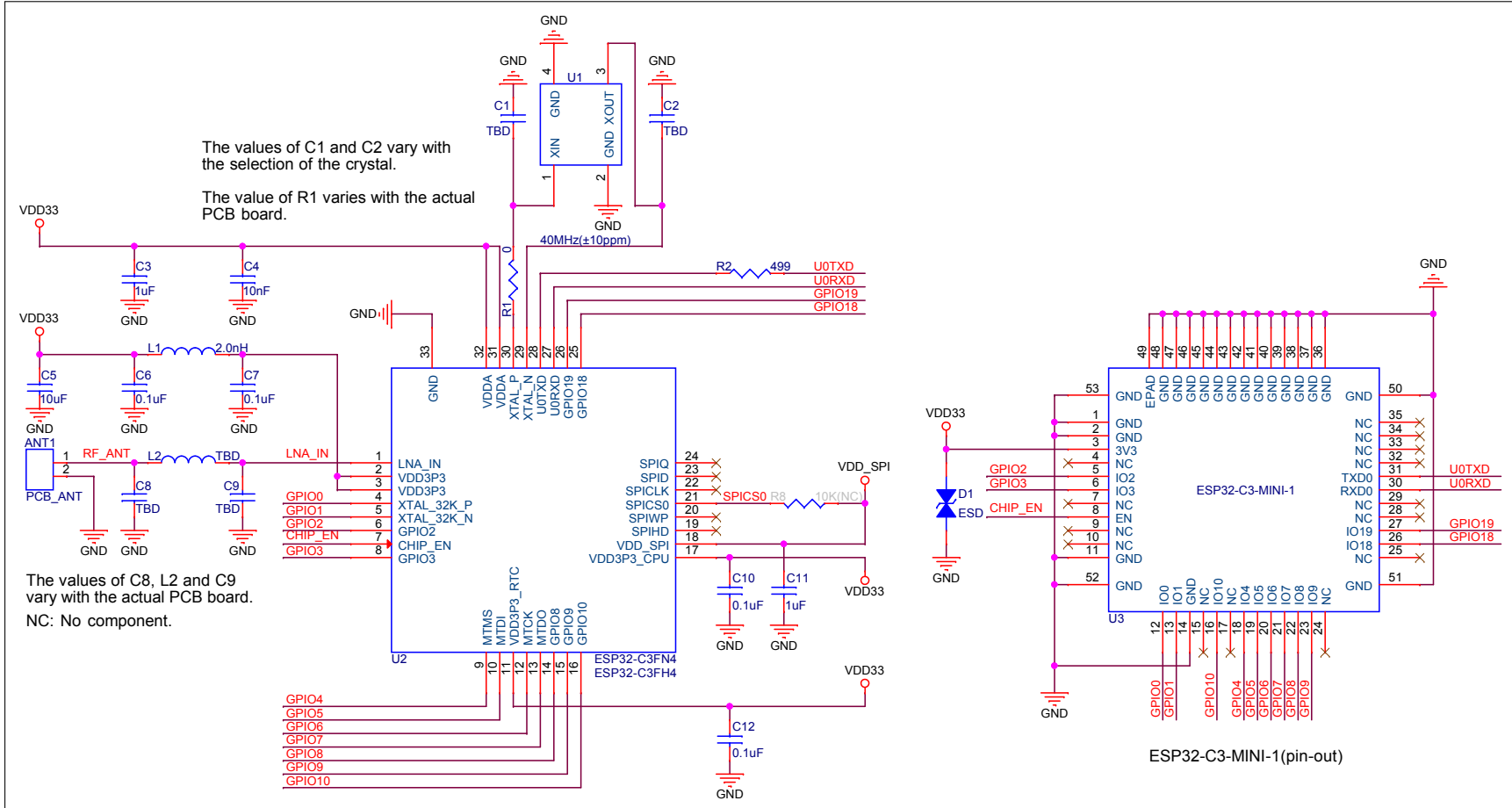

Figure 5: ESP32-C3-MINI-1 Schematics

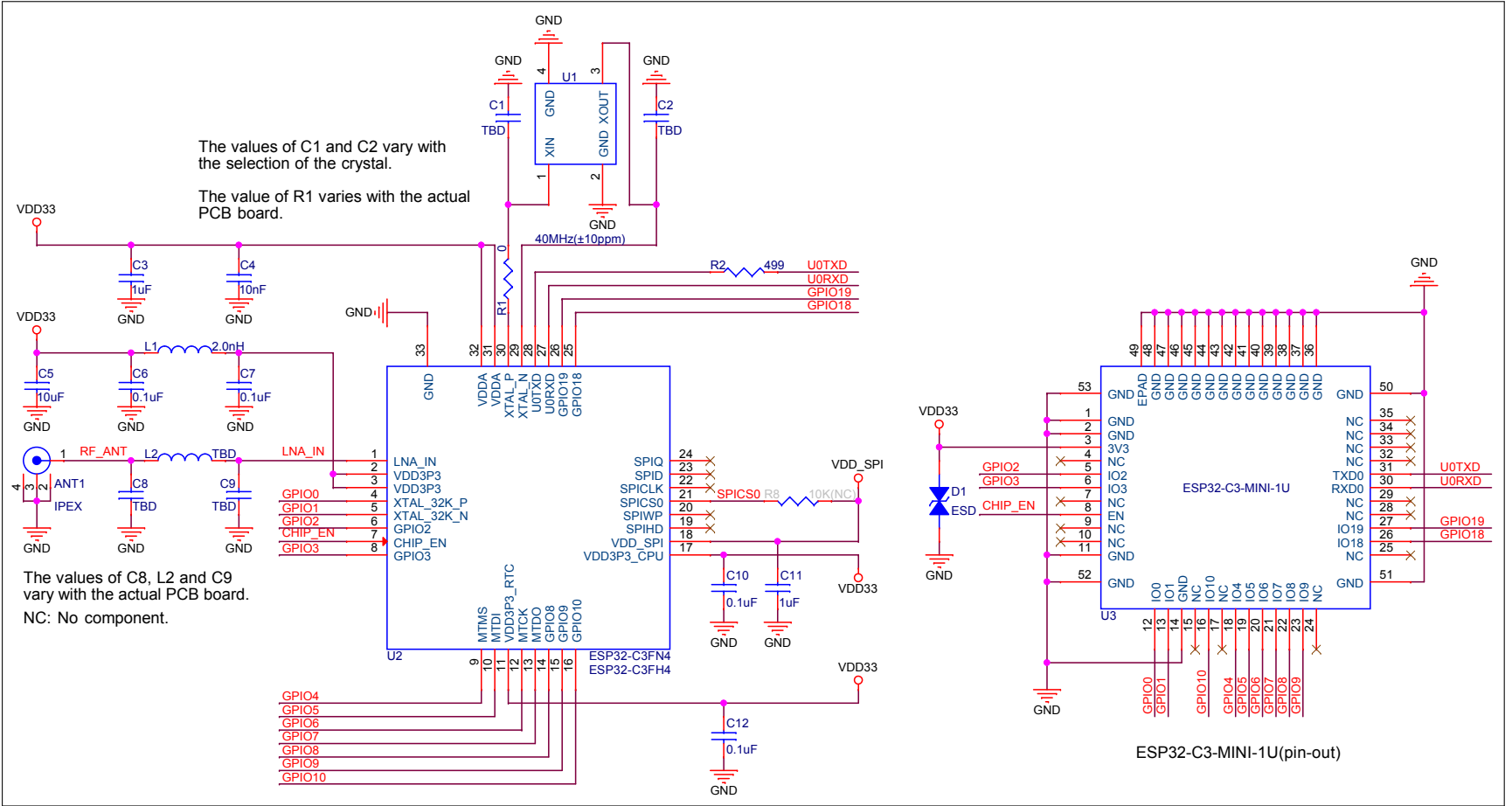

Figure 6: ESP32-C3-MINI-1U Schematics

6 Peripheral Schematics

This is the typical application circuit of the module connected with peripheral components (for example, power supply, antenna, reset button, JTAG interface, and UART interface).

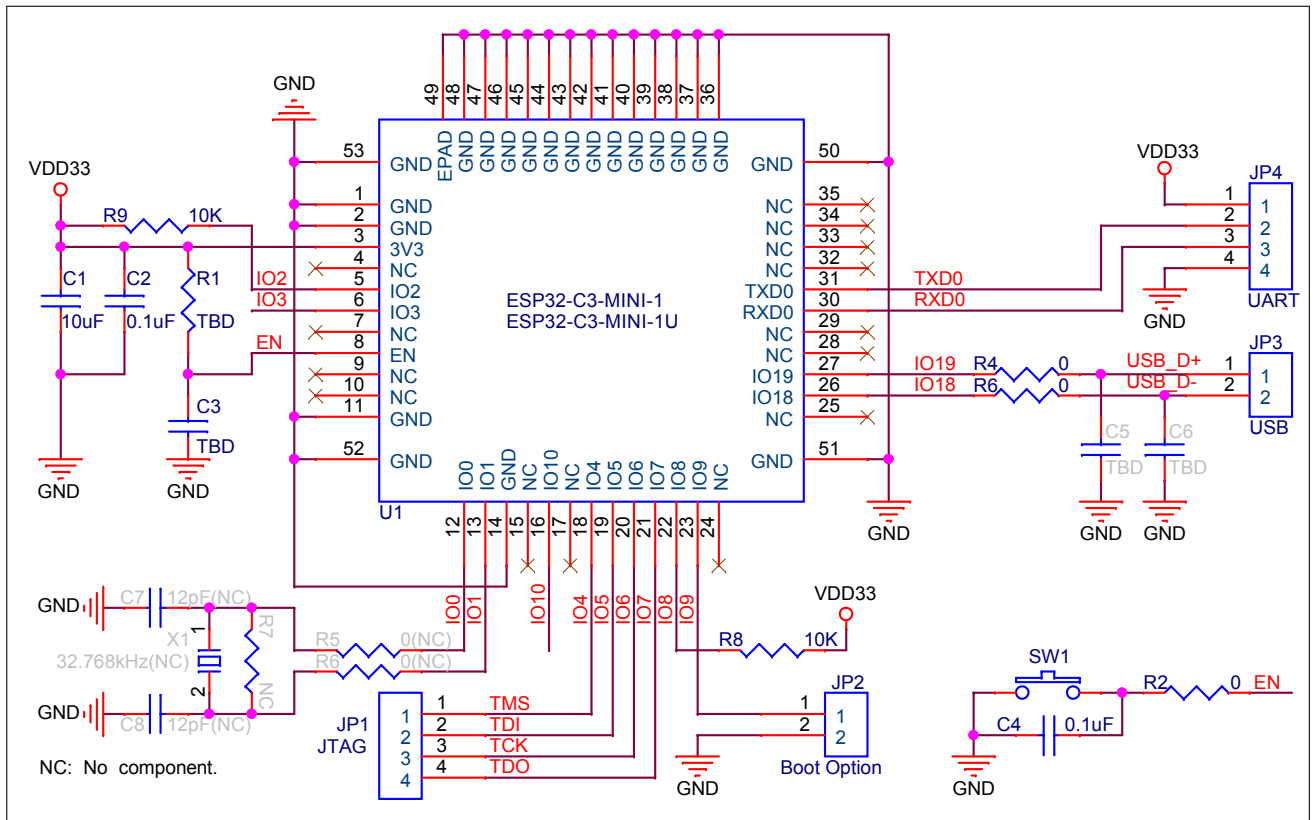

Figure 7: Peripheral Schematics

- Soldering the EPAD to the ground of the base board is not a must, however, it can optimize thermal performance. If you choose to solder it, please apply the correct amount of soldering paste.
- To ensure that the power supply to the ESP32-C3 chip is stable during power-up, it is advised to add an RC delay circuit at the EN pin. The recommended setting for the RC delay circuit is usually $R = 10\text{ k}\Omega$ and $C = 1\text{ }\mu\text{F}$. However, specific parameters should be adjusted based on the power-up timing of the module and the power-up and reset sequence timing of the chip. For ESP32-C3's power-up and reset sequence timing diagram, please refer to Section *Power Scheme* in [ESP32-C3 Series Datasheet](#).

7 Physical Dimensions and PCB Land Pattern

7.1 Physical Dimensions

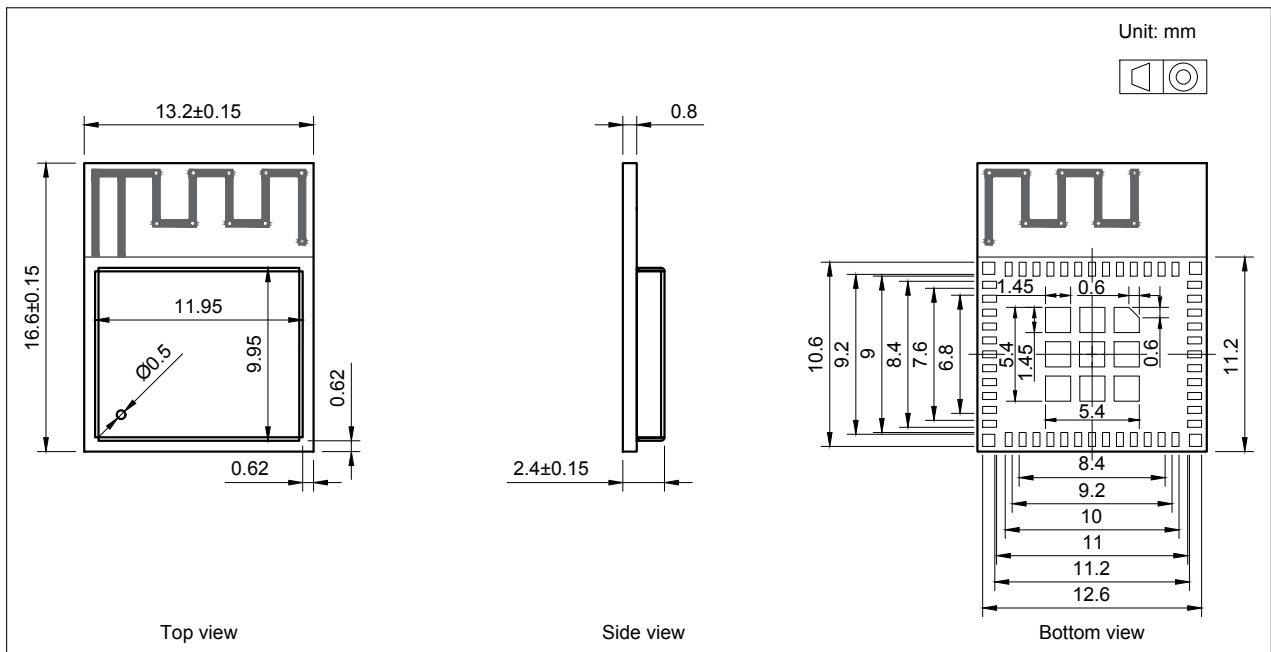

Figure 8: ESP32-C3-MINI-1 Physical Dimensions

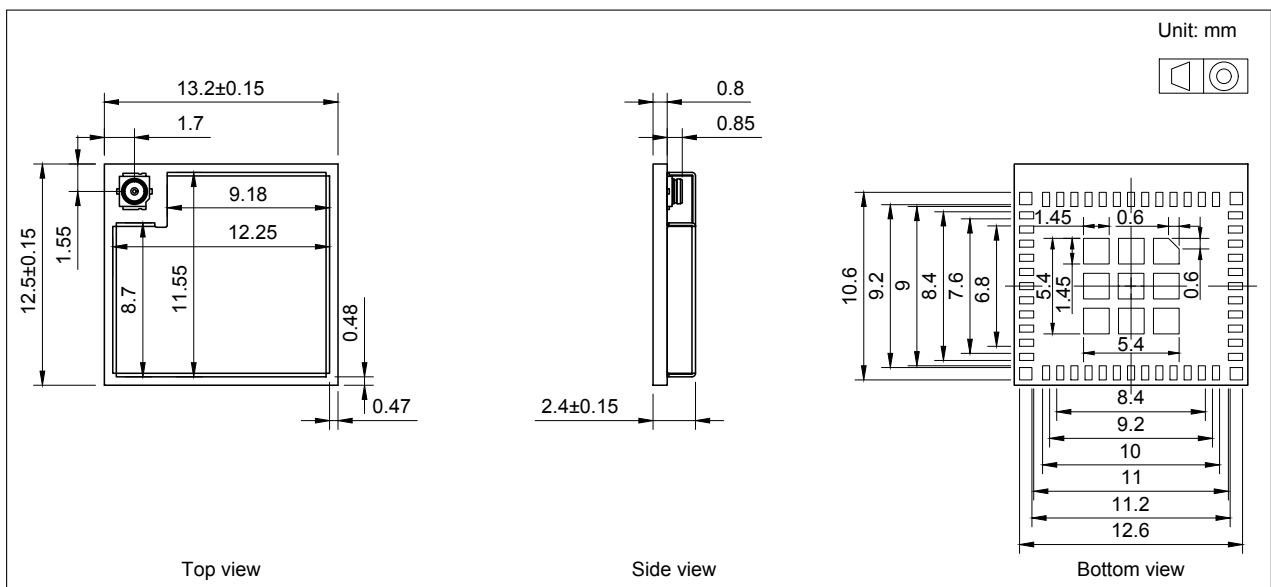

Figure 9: ESP32-C3-MINI-1U Physical Dimensions

Note:

For information about tape, reel, and product marking, please refer to [Espressif Module Package Information](#).

7.2 Recommended PCB Land Pattern

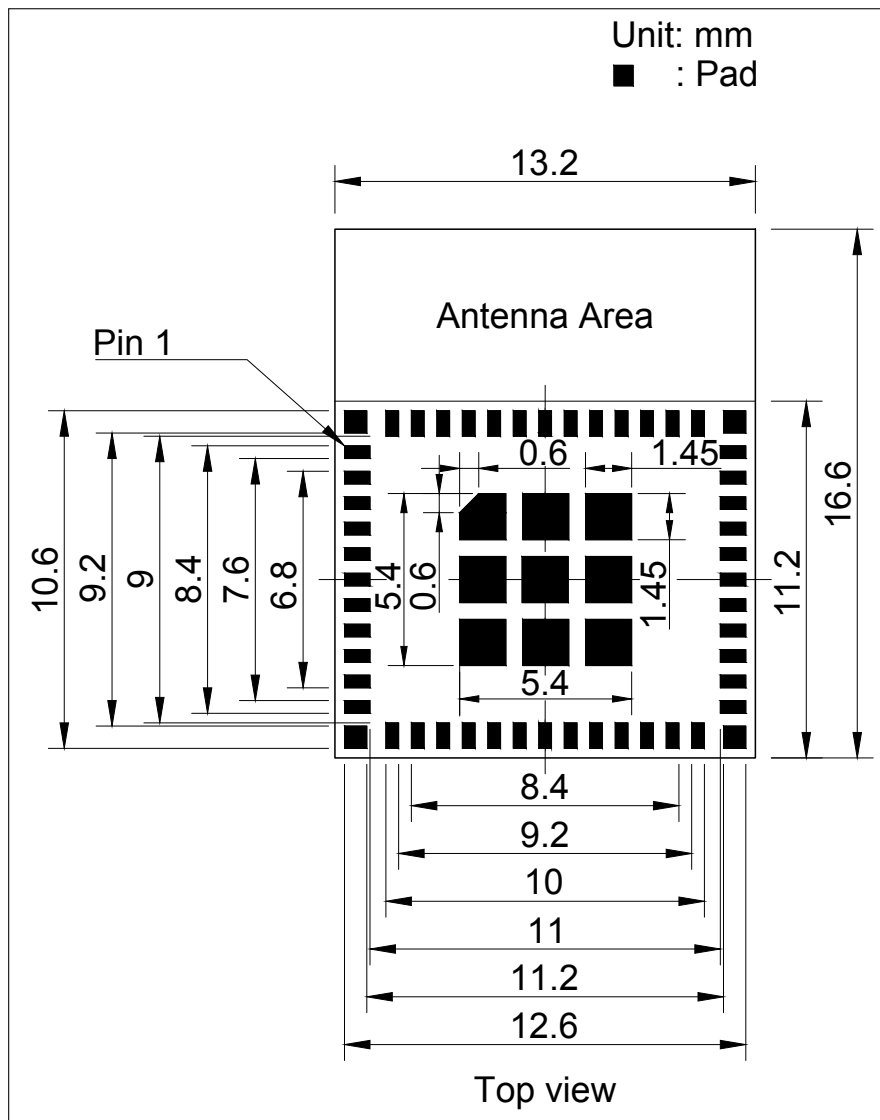

Figure 10: ESP32-C3-MINI-1 Recommended PCB Land Pattern

7.3 Dimensions of External Antenna Connector

ESP32-C3-MINI-1U uses the third generation external antenna connector. This connector is compatible with the following connectors:

- W.FL Series connector from Hirose
- MHF III connector from I-PEX
- AMMC connector from Amphenol

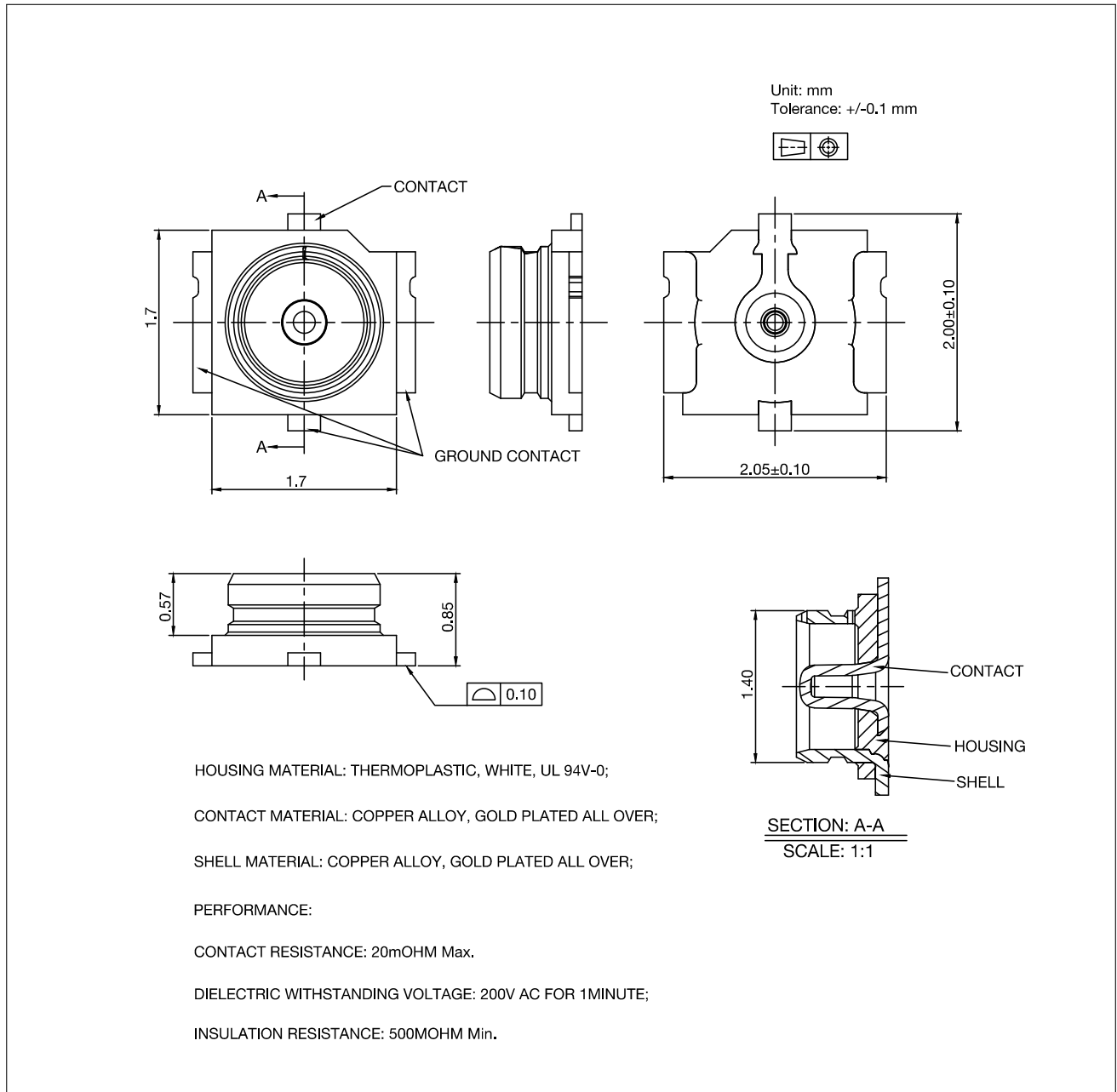

Figure 12: Dimensions of External Antenna Connector

8 Product Handling

8.1 Storage Conditions

The products sealed in moisture barrier bags (MBB) should be stored in a non-condensing atmospheric environment of $< 40\text{ }^{\circ}\text{C}$ and $/90\%\text{RH}$. The module is rated at the moisture sensitivity level (MSL) of 3.

After unpacking, the module must be soldered within 168 hours with the factory conditions $25\pm 5\text{ }^{\circ}\text{C}$ and $/60\%\text{RH}$. If the above conditions are not met, the module needs to be baked.

8.2 Electrostatic Discharge (ESD)

- Human body model (HBM): 2000 V
- Charged-device model (CDM): 500 V
- Air discharge: 6000 V
- Contact discharge: 4000 V

8.3 Reflow Profile

Solder the module in a single reflow.

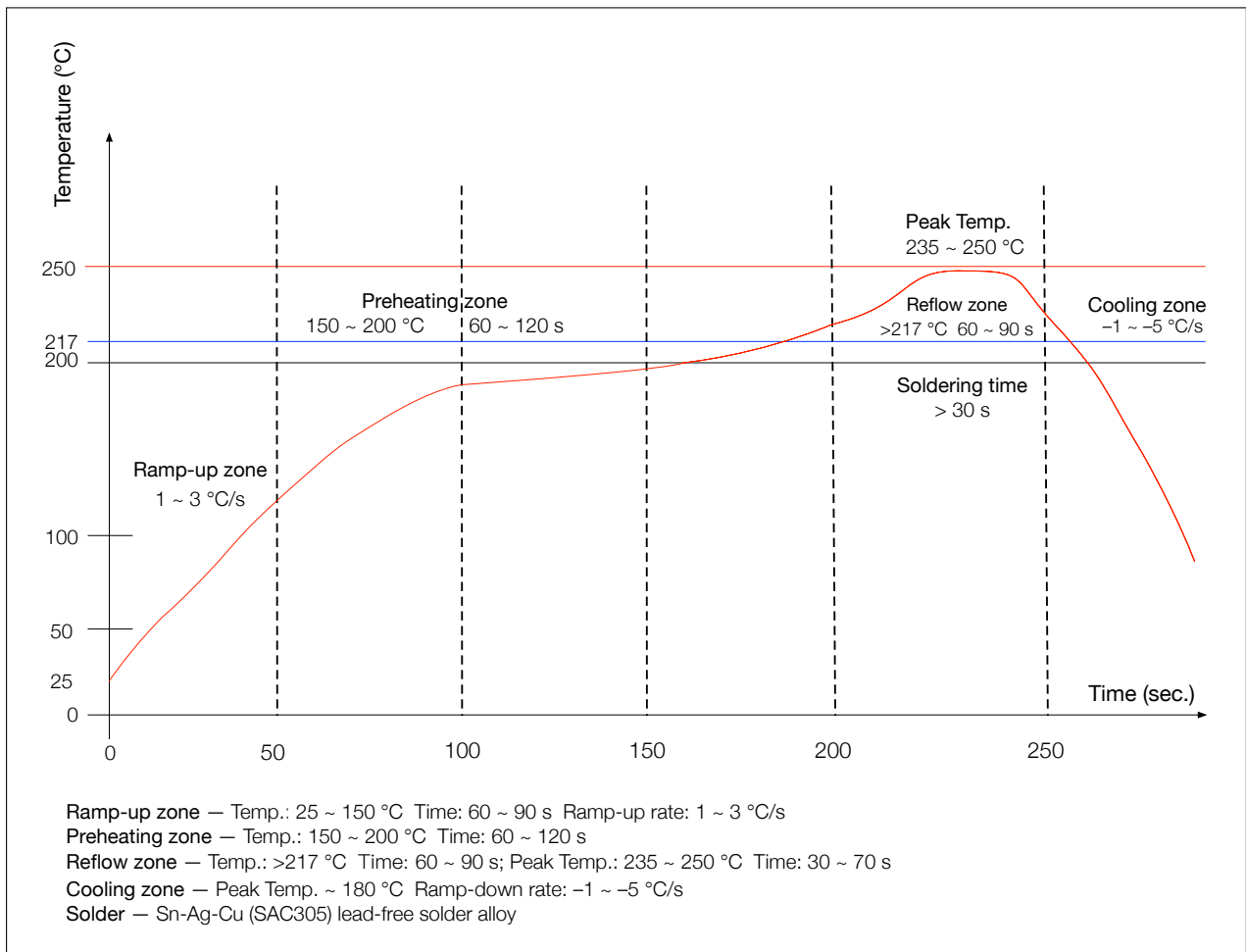

Figure 13: Reflow Profile

9 Related Documentation and Resources

Related Documentation

- [ESP32-C3 Technical Reference Manual](#) – Detailed information on how to use the ESP32-C3 memory and peripherals.
- [ESP32-C3 Series Datasheet](#) – Specifications of the ESP32-C3 hardware.
- *Certificates*
<http://espressif.com/en/support/documents/certificates>
- *Documentation Updates and Update Notification Subscription*
<http://espressif.com/en/support/download/documents>

Developer Zone

- [ESP-IDF Programming Guide for ESP32-C3](#) – Extensive documentation for the ESP-IDF development framework.
- *ESP-IDF* and other development frameworks on GitHub.
<http://github.com/espressif>
- *ESP32 BBS Forum* – Engineer-to-Engineer (E2E) Community for Espressif products where you can post questions, share knowledge, explore ideas, and help solve problems with fellow engineers.
<http://esp32.com/>
- *The ESP Journal* – Best Practices, Articles, and Notes from Espressif folks.
<http://medium.com/the-esp-journal>
- See the tabs *SDKs and Demos, Apps, Tools, AT Firmware*.
<http://espressif.com/en/support/download/sdks-demos>

Products

- *ESP32-C3 Series SoCs* – Browse through all ESP32-C3 SoCs.
<http://espressif.com/en/products/socs?id=ESP32-C3>
- *ESP32-C3 Series Modules* – Browse through all ESP32-C3-based modules.
<http://espressif.com/en/products/modules?id=ESP32-C3>
- *ESP32-C3 Series DevKits* – Browse through all ESP32-C3-based devkits.
<http://espressif.com/en/products/devkits?id=ESP32-C3>
- *ESP Product Selector* – Find an Espressif hardware product suitable for your needs by comparing or applying filters.
<http://products.espressif.com/#/product-selector?language=en>

Contact Us

- See the tabs *Sales Questions, Technical Enquiries, Circuit Schematic & PCB Design Review, Get Samples (Online stores), Become Our Supplier, Comments & Suggestions*.
<http://espressif.com/en/contact-us/sales-questions>

Revision History

Date	Version	Release notes
2021-06-21	V1.0	<ul style="list-style-type: none">• Updated module description on the title page• Deleted Section "About This Document"• Restructured Section 1.1 Features• Added ordering code in Table 2 Ordering Information• Added descriptions in Section 7.3 Dimensions of External Antenna Connector• Updated Section "Learning Resources" and renamed to "Related Documentation and Resources"• Replaced "chip family" with "chip series" following Espressif's taxonomy
2021-04-16	V0.7	Added information about ESP32-C3-MINI-1U module
2021-02-22	V0.6	Updated the value of C7 to 0.1 μ F in Chapter 5 Module Schematics
2021-02-05	V0.5	Preliminary release



www.espressif.com

Disclaimer and Copyright Notice

Information in this document, including URL references, is subject to change without notice.

ALL THIRD PARTY'S INFORMATION IN THIS DOCUMENT IS PROVIDED AS IS WITH NO WARRANTIES TO ITS AUTHENTICITY AND ACCURACY.

NO WARRANTY IS PROVIDED TO THIS DOCUMENT FOR ITS MERCHANTABILITY, NON-INFRINGEMENT, FITNESS FOR ANY PARTICULAR PURPOSE, NOR DOES ANY WARRANTY OTHERWISE ARISING OUT OF ANY PROPOSAL, SPECIFICATION OR SAMPLE.

All liability, including liability for infringement of any proprietary rights, relating to use of information in this document is disclaimed. No licenses express or implied, by estoppel or otherwise, to any intellectual property rights are granted herein.

The Wi-Fi Alliance Member logo is a trademark of the Wi-Fi Alliance. The Bluetooth logo is a registered trademark of Bluetooth SIG.

All trade names, trademarks and registered trademarks mentioned in this document are property of their respective owners, and are hereby acknowledged.

Copyright © 2021 Espressif Systems (Shanghai) Co., Ltd. All rights reserved.