

**EN** GPS module u-blox NEO-7M for Arduino®

WPI430



## Introduction



### **To all residents of the European Union Important environmental information about this product**

This symbol on the device or the package indicates that disposal of the device after its lifecycle could harm the environment. Do not dispose of the unit (or batteries) as unsorted municipal waste; it should be taken to a specialized company for recycling. This device should be returned to your distributor or to a local recycling service. Respect the local environmental rules.

**If in doubt, contact your local waste disposal authorities.**

Thank you for choosing Whadda! Please read the manual thoroughly before bringing this device into service. If the device was damaged in transit, do not install or use it and contact your dealer.

## Safety Instructions



Read and understand this manual and all safety signs before using this appliance.



For indoor use only.

- This device can be used by children aged from 8 years and above, and persons with reduced physical, sensory or mental capabilities or lack of experience and knowledge if they have been given supervision or instruction concerning the use of the device in a safe way and understand the hazards involved. Children shall not play with the device. Cleaning and user maintenance shall not be made by children without supervision.

## General Guidelines

- Refer to the Velleman® Service and Quality Warranty on the last pages of this manual.
- All modifications of the device are forbidden for safety reasons. Damage caused by user modifications to the device is not covered by the warranty.
- Only use the device for its intended purpose. Using the device in an unauthorized way will void the warranty.
- Damage caused by disregard of certain guidelines in this manual is not covered by the warranty and the dealer will not accept responsibility for any ensuing defects or problems.
- Nor Velleman Group nv nor its dealers can be held responsible for any damage (extraordinary, incidental or indirect) – of any nature (financial, physical...) arising from the possession, use or failure of this product.
- Keep this manual for future reference.

## What is Arduino®

Arduino® is an open-source prototyping platform based on easy-to-use hardware and software. Arduino® boards are able to read inputs – light-on sensor, a finger on a button or a Twitter message – and turn it into an output – activating of a motor, turning on an LED, publishing something online. You can tell your board what to do by sending a set of instructions to the microcontroller on the board. To do so, you use the Arduino programming language (based on Wiring) and the Arduino® software IDE (based on Processing). Additional shields/modules/components are required for reading a twitter message or publishing online. Surf to [www.arduino.cc](http://www.arduino.cc) for more information.

## RED Declaration of Conformity

Hereby, Velleman Group nv declares that the radio equipment type WPI430 is in compliance with Directive 2014/53/EU.

The full text of the EU declaration of conformity is available at the following internet address: [www.velleman.eu](http://www.velleman.eu).

## Product Overview

The NEO-7 series of standalone GNSS modules is built on the exceptional performance of the u-blox 7 GNSS (GPS, GLONASS, QZSS and SBAS) engine. The NEO-7 series delivers high sensitivity and minimal acquisition times in the industry-proven NEO form factor. The Whadda WPI430 GPS module uses the u-blox NEO-M chipset at its core in order to provide accurate location data with low acquisition times. It features a built-in USB connector to directly interface with PCs, a built-in ceramic patch antenna (suitable for outdoor uses), and an external SMA antenna connector. It is advised to remove the C2 capacitor when connecting an external GPS antenna in order to avoid interference.

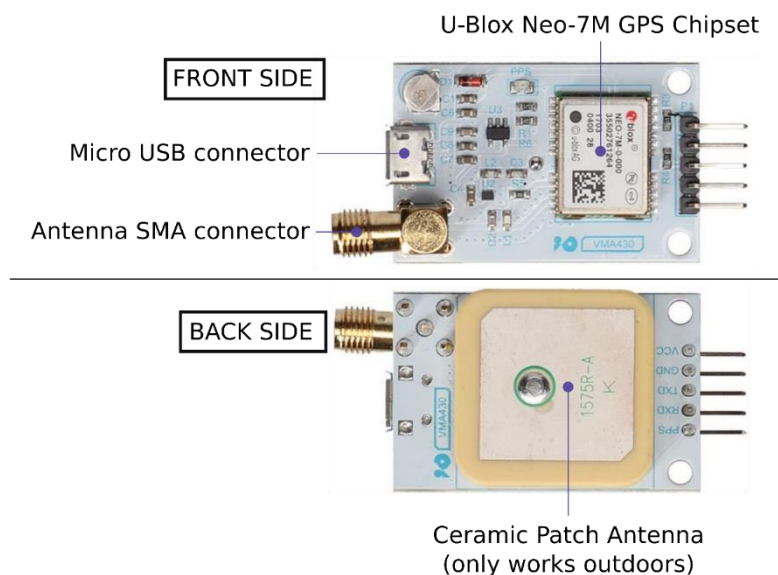

## Specifications

- supply voltage: 3.3-5 VDC (or by USB cable)
- connections: VCC (+5 V), GND (ground), TX, RX, PPS (time pulse)
- default baud rate: 9600 baud
- dimensions: 4 x 2.5 x 1.5 cm
- weight: 15 g

## Features

- u-blox NEO-7M module, compact and excellent performance
- parameters can be set via serial port and saved in EEPROM
- with SMA interface, you can connect a variety of antenna, strong adaptability
- compatible with 3.3 V/5 V level for easy connection to a variety of microprocessor systems
- back-up rechargeable battery on board
- with microUSB, no need for USB-TTL tools
- with TTL interface
- onboard ceramic antenna
- sample code: <https://playground.arduino.cc/UBlox/GPS>
- evaluation software (u-center) available for download

## Using the Module Directly with a PC

You can directly connect the GPS module to your PC by using a microUSB cable.

To check the raw incoming data, you can use the Arduino® IDE's serial monitor. Make sure that the port settings are set to the correct serial port, and the baud rate is set to 9600 baud.

The messages starting with a dollar sign '\$' are NMEA messages that can be read by a variety of software such as google earth.

You can quickly check the data by copying the NMEA messages into an online NMEA decoder, e.g. <http://freenmea.net/decoder>.

## Connection

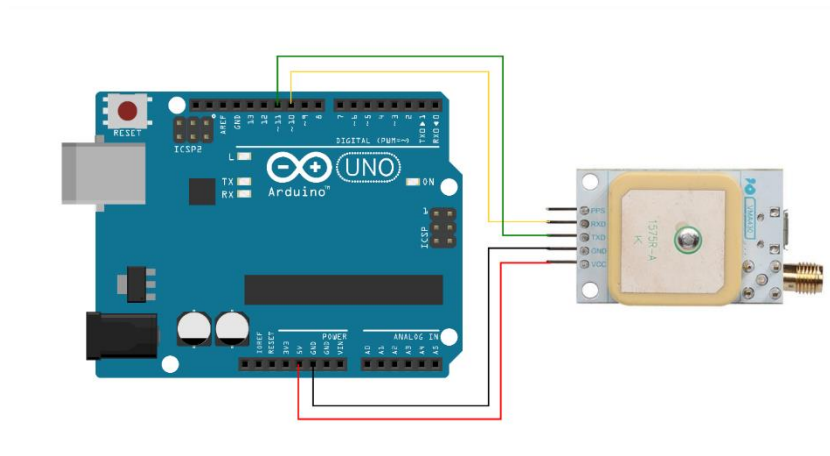

## Example

Library and examples can be found at [https://github.com/Velleman/VMA430\\_GPS\\_Module](https://github.com/Velleman/VMA430_GPS_Module).



[whadda.com](http://whadda.com)