

Features

- ★ Split Gate Trench MOSFET technology
- ★ Excellent package for heat dissipation
- ★ High density cell design for low RDS(ON)

Product Summary

RoHS

BVDSS	RDSON	ID
100V	4.5mΩ	100A

Description

- ★ DC-DC Converters
- ★ Power management functions
- ★ Synchronous-rectification applications

PDFN5*6 Pin Configuration

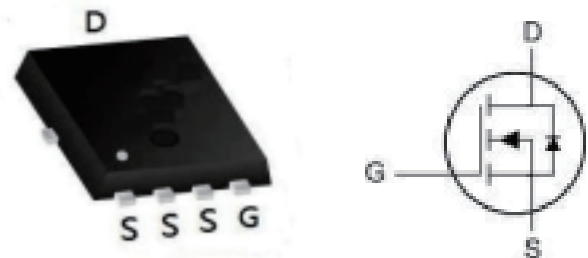

Absolute Maximum Ratings

Symbol	Parameter	Max.	Unit	
V _{DSS}	Drain-Source Voltage	100	V	
V _{GSS}	Gate-Source Voltage	±20	V	
I _D	Continuous Drain Current	T _c = 25°C	100	A
		T _c = 100°C	60	A
I _{DM}	Pulsed Drain Current ^{note1}	380	A	
E _{AS}	Single Pulsed Avalanche Energy ^{note2}	205	mJ	
P _D	Power Dissipation	T _c = 25°C	113.6	W
R _{θJA}	Thermal Resistance from Junction-to-Ambient ³	58	°C/W	
R _{θJC}	Thermal Resistance, Junction to Case	1.1	°C/W	
T _J , T _{STG}	Operating and Storage Temperature Range	-55 to +150	°C	

Electrical Characteristics ($T_J = 25^\circ\text{C}$ unless otherwise specified)

Symbol	Parameter	Test condition	Min.	Typ.	Max.	Units
Static Characteristics						
$V_{(BR)DSS}$	Drain-Source Breakdown Voltage	$V_{GS} = 0V, I_D = 250\mu A$	100	-	-	V
I_{GSS}	Gate-body Leakage current	$V_{DS} = 0V, V_{GS} = \pm 20V$	-	-	± 100	nA
I_{DSS}	Zero Gate Voltage Drain Current	$V_{DS} = 100V, V_{GS} = 0V$	$T_J = 25^\circ\text{C}$	-	1	μA
			$T_J = 100^\circ\text{C}$	-	100	
$V_{GS(th)}$	Gate-Threshold Voltage	$V_{DS} = V_{GS}, I_D = 250\mu A$	1.2	1.8	2.5	V
$R_{DS(on)}$	Drain-Source on-Resistance ⁴	$V_{GS} = 10V, I_D = 20A$	-	4.5	6	m Ω
		$V_{GS} = 4.5V, I_D = 15A$	-	6.6	9	
Dynamic Characteristics⁵						
C_{iss}	Input Capacitance	$V_{DS} = 50V, V_{GS} = 0V,$ $f = 1MHz$	-	4400	-	pF
C_{oss}	Output Capacitance		-	645	-	
C_{rss}	Reverse Transfer Capacitance		-	20	-	
Switching Characteristics⁵						
R_g	Gate Resistance	$V_{GS} = 0V, V_{DS} = 0V,$ $f = 1MHz$	-	1.7	-	Ω
Q_g	Total Gate Charge	$V_{GS} = 10V, V_{DS} =$ $50V, I_D = 20A$	-	75	-	nC
Q_{gs}	Gate-Source Charge		-	17	-	
Q_{gd}	Gate-Drain Charge		-	13	-	
$t_{d(on)}$	Turn-on Delay Time	$V_{GS} = 10V, V_{DS}$ $= 50V, R_G = 3\Omega, I_D =$ $20A$	-	15.4	-	ns
t_r	Rise Time		-	13	-	
$t_{d(off)}$	Turn-off Delay Time		-	34	-	
t_f	Fall Time		-	6.2	-	
t_{rr}	Body Diode Reverse Recovery Time	$I_F = 20A,$ $dI/dt = 100A/\mu s$	-	55	-	nC
Q_{rr}	Body Diode Reverse Recovery Charge		-	101	-	
Drain-Source Body Diode Characteristics						
V_{SD}	Diode Forward Voltage ⁴	$I_S = 20A, V_{GS} = 0V$	-	-	1.2	V
I_S	Continuous Source Current	$T_C = 25^\circ\text{C}$	-	-	95	A

Notes:

- 1.Repetitive rating, pulse width limited by junction temperature $T_{J(MAX)} = 150^\circ\text{C}$.
- 2.The EAS data shows Max. rating . The test condition is $V_{DD} = 25V, V_{GS} = 10V, L = 0.4mH, I_{AS} = 40A$.
- 3.The data tested by surface mounted on a 1 inch² FR-4 board with 2OZ copper, The value in any given application depends on the user's specific board design.
- 4.The data tested by pulsed , pulse width $\leq 300\mu s$, duty cycle $\leq 2\%$.
- 5.This value is guaranteed by design hence it is not included in the production test.

Typical Electrical and Thermal Characteristics (Curves)

Figure 1: Output Characteristics

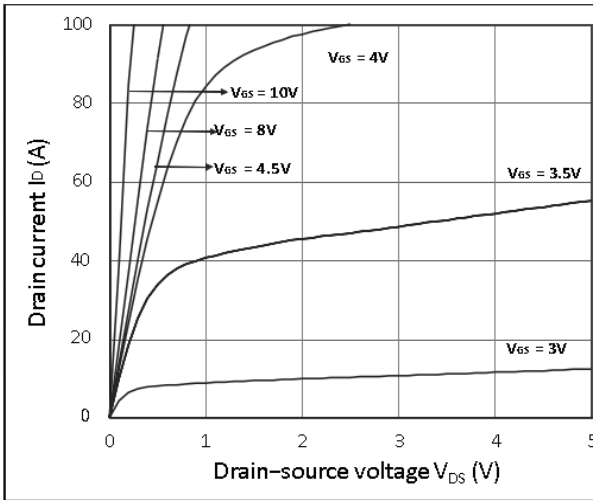

Figure 2: Typ. Transfer Characteristics

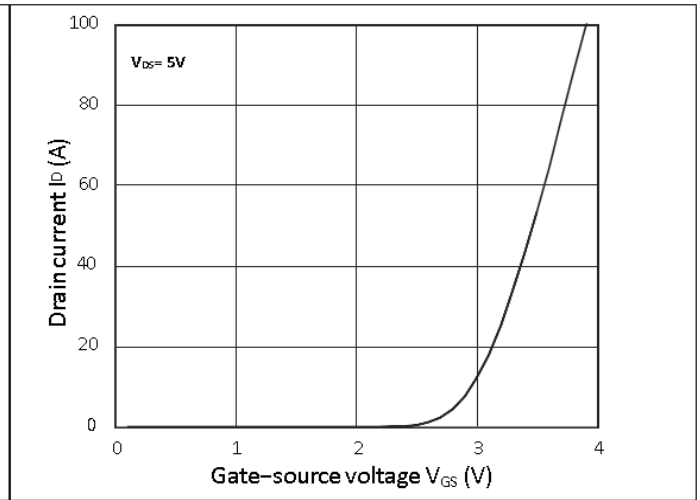

Figure 3: Forward Characteristics of Reverse

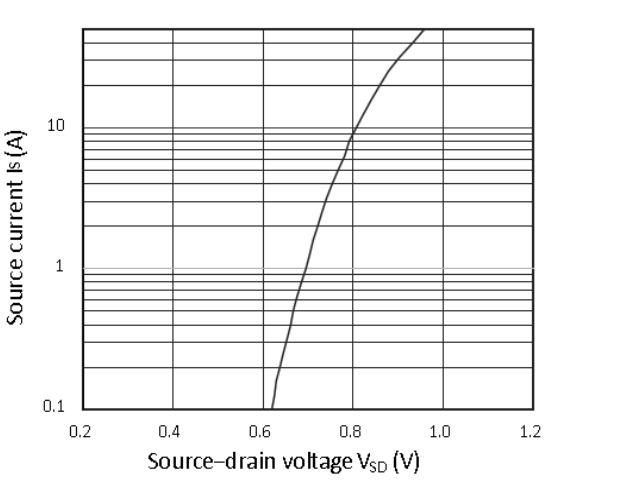

Figure 4: RDS(ON) vs. VGS

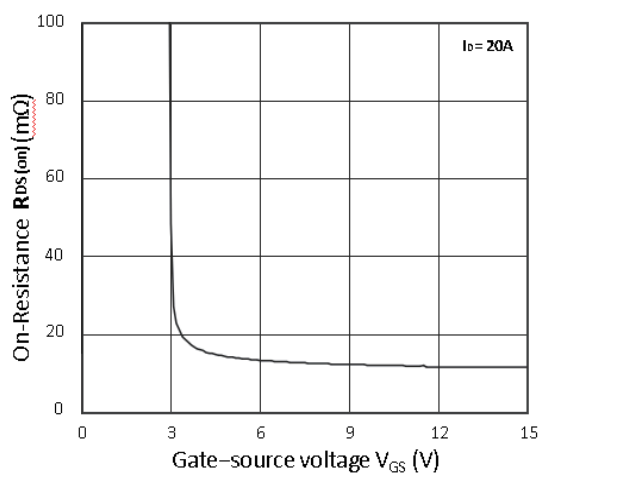

Figure 5: RDS(ON) vs. ID

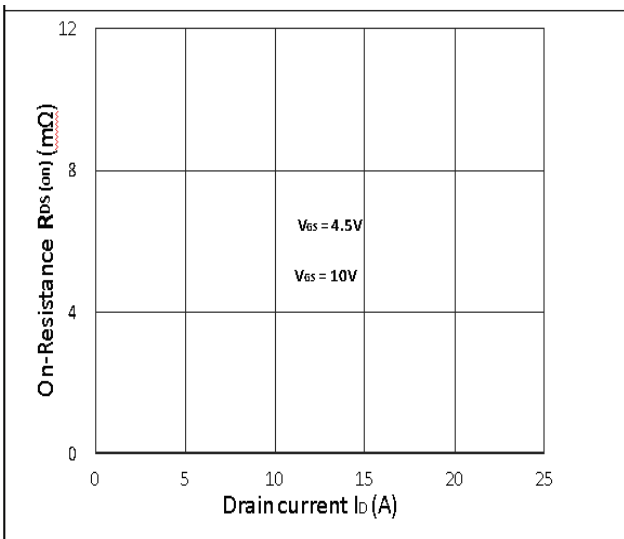
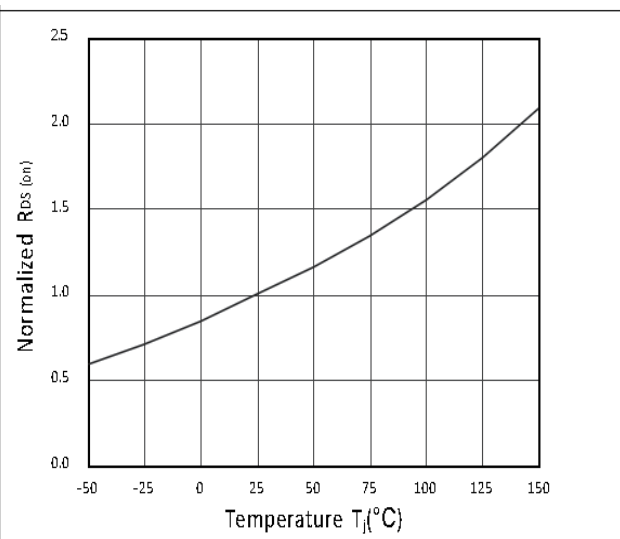

Figure 6: Normalized RDS(on) vs. Temperature



Typical Performance Characteristics

Figure 7: Capacitance Characteristics

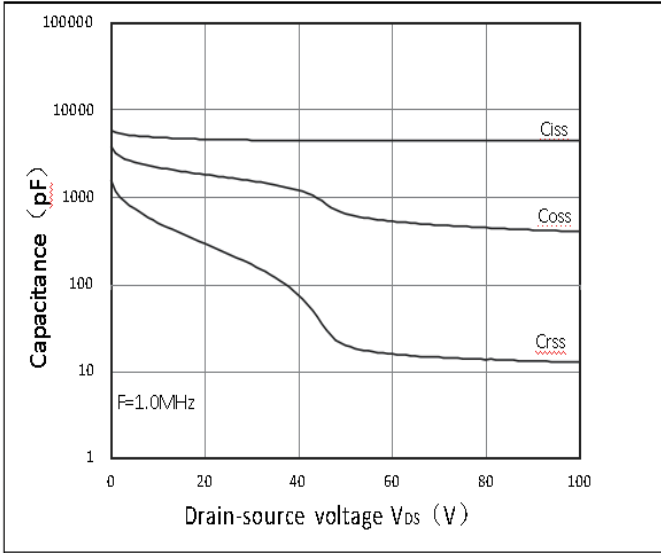

Figure 8: Gate Charge Characteristics

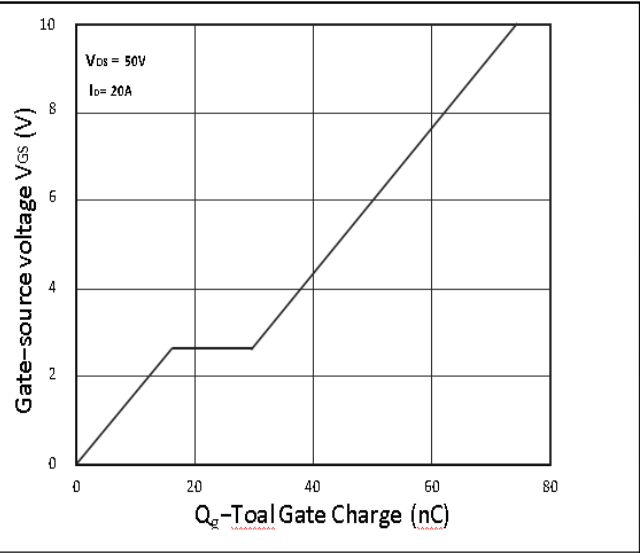

Figure 9: Power Dissipation

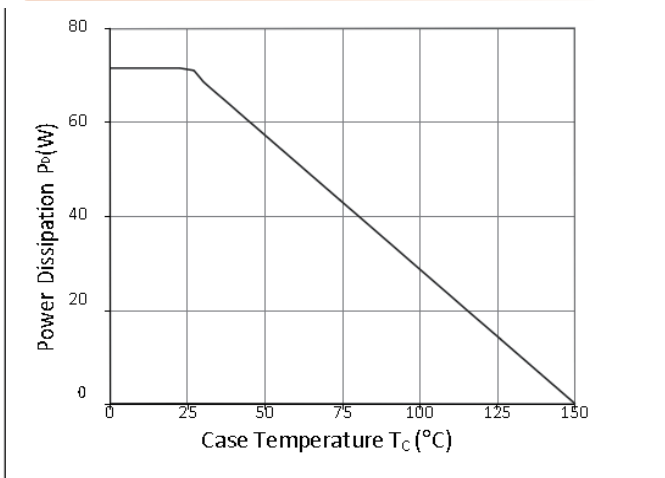

Figure 10: Safe Operating Area

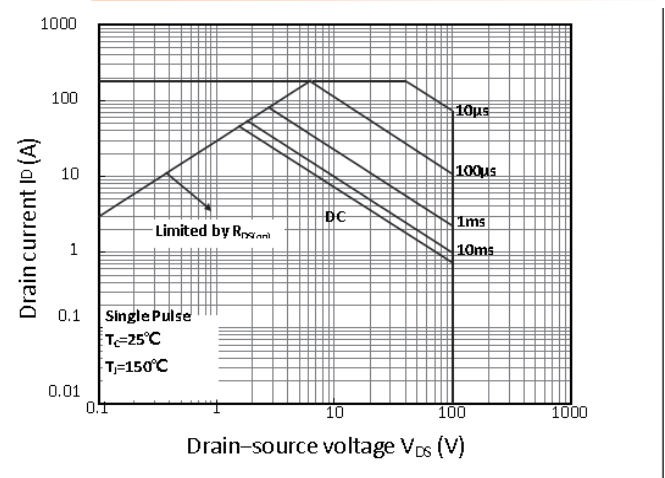
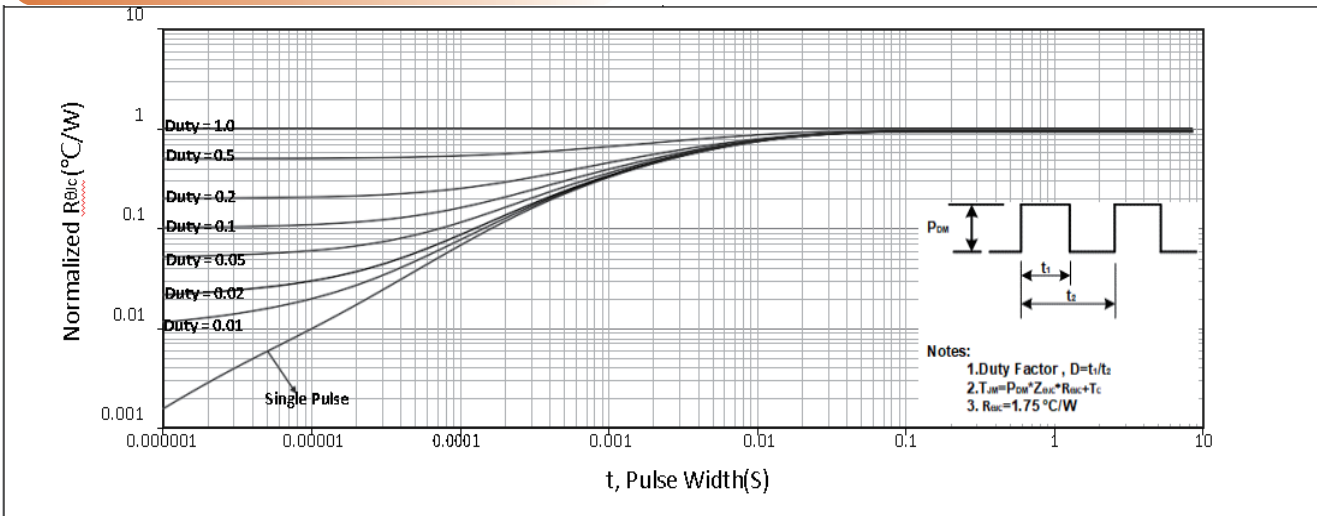

Figure 11: Normalized Maximum Transient Thermal Impedance



Test Circuit and Waveform

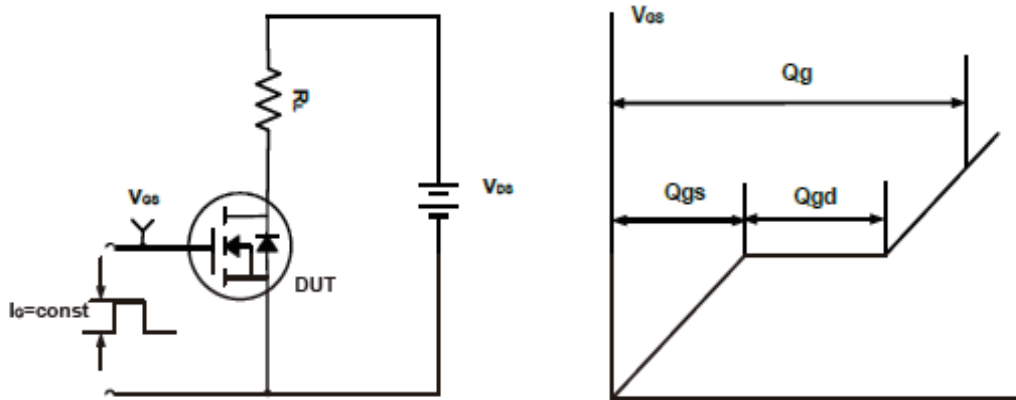

Figure A. Gate Charge Test Circuit & Waveforms

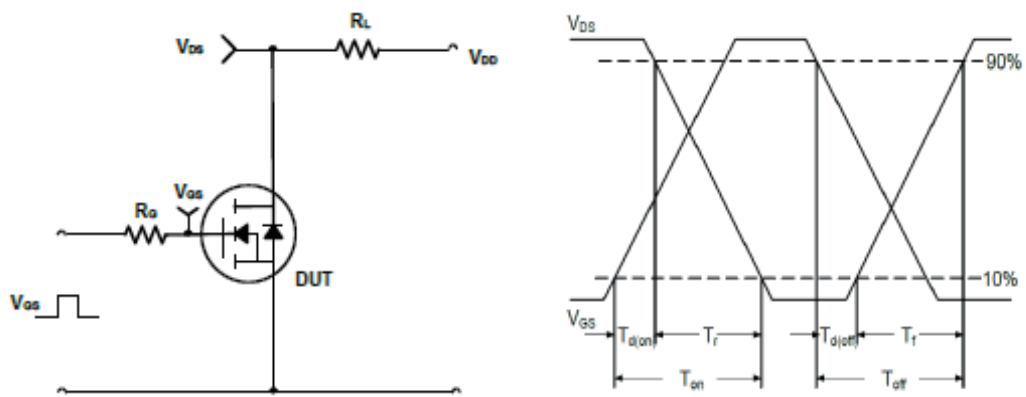

Figure B. Switching Test Circuit & Waveforms

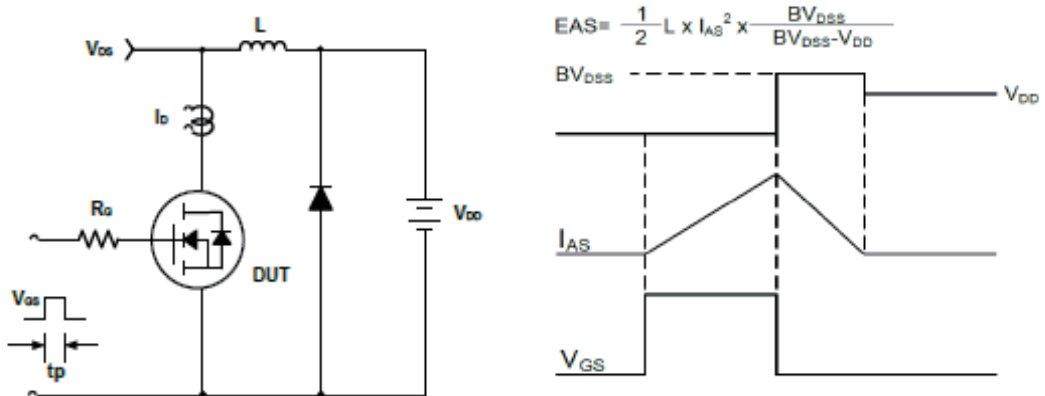
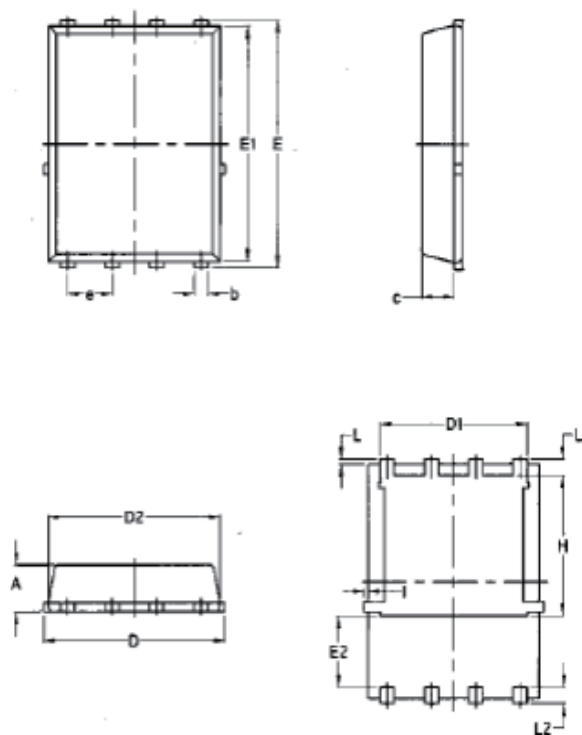

Figure C. Unclamped Inductive Switching Circuit & Waveforms

Package Mechanical Data-DFN5*6-8L-Single



Symbol	Common			
	mm		Inch	
	Min	Max	Min	Max
A	1.03	1.17	0.0406	0.0461
b	0.34	0.48	0.0134	0.0189
c	0.824	0.0970	0.0324	0.082
D	4.80	5.40	0.1890	0.2126
D1	4.11	4.31	0.1618	0.1697
D2	4.80	5.00	0.1890	0.1969
E	5.95	6.15	0.2343	0.2421
E1	5.65	5.85	0.2224	0.2303
E2	1.60	/	0.0630	/
e	1.27 BSC		0.05 BSC	
L	0.05	0.25	0.0020	0.0098
L1	0.38	0.50	0.0150	0.0197
L2	0.38	0.50	0.0150	0.0197
H	3.30	3.50	0.1299	0.1378
I	/	0.18	/	0.0070